



μFLOW 100WT

compact calculator for water and steam

Instruction manual

August 2002

Valid from software version WT-1.9917

UFW002-04.doc

S.K.I Schlegel & Kremer Industrieautomation GmbH
Gerberstr. 49 - 41199 Mönchengladbach
phone: ++49/2166/62317-0 - fax: ++49/2166/611681

doc-no.: BA-UFW002-04.doc

content

<i>Explanations of symbols</i>	2
<i>General Hints</i>	2
<i>Qualified Personnel</i>	2
<i>Technical data</i>	3
Dimensions	3
Mechanical mounting	3
Cleaning	4
General hints for Electrical connection	4
Connection examples for inputs	4
Connection examples for the output	5
The terminals in detail	6
Choosing the signal for the temperature input (Pt100 or current)	7
Exchange of the fuses	7
<i>The displays</i>	8
<i>Menu tree</i>	9
Short example for changing parameter value	11
Access	11
Water alarm – menu point %Wetstm (level C/13)	11
Sensorbyte – menu point SENSORS (Level C/65)	11
k-Factor – Menu point k-factor (level D/7)	12
The transfer characteristic	12
<i>Application of the RS232 Interface</i>	12
Link and control of the μ FLOW with a PC	12
Adjusting the Baudrate - menu option BAUD (level D/46)	12
Adjusting the duration of the transmission cycle	12
Parameters	12
Protocol	13
Data format	13
<i>Trouble shooting</i>	14
Description of the failure	14
Possible reason	14
<i>EC-Declaration of Conformity</i>	15

Explanations of symbols



Warning of a danger place (caution: consider documentation)
ISO 3864, No. B.3.1



Warning of dangerous electrical voltage
ISO 3864, No. B.3.6

General Hints

For reasons of clarity this manual does not contain detailed information about all types of products and cannot take into account every conceivable case of installation, operation or maintenance.

If you require further information or should problems occur which are not sufficiently explained in the manual, you can consult us directly to obtain the necessary information.



CAUTION

This equipment is a Limit Class A once. It can cause radio disturbance in residential. On this case customer has to take care appropriate measure.

This equipment should only be installed and operated after qualified personnel have ensured that suitable power supply (see name plate) will be used and that during normal operation or in case of a defect in the system or in components no hazardous situation can occur. Therefore serious injuries and/or considerable material damage cannot be ruled out in the event of improper handling of the device.

The perfect and safe operation of this equipment is conditional upon proper transport, proper storage, installation and assembly as well as on careful operation and commissioning.

May we also draw your attention to the fact that the contents of the manual are not part of a previous or existing agreement, approval or legal relationship or an amendment thereof. All obligations of the S.K.I. GmbH result from the contract of purchase which also contains the full and solely valid warranty agreement. These contractual warranty conditions are neither extended nor restricted by the contents of the manual.

Qualified Personnel

are persons familiar with the installation, assembly, commissioning and operation of the product and who have the appropriate qualifications for their activities such as:



- Training or instruction or authorization to operate and maintain devices/systems according to the standard of safety technology for electrical installations.
- Training or instruction in the proper care and use of protective equipment in accordance with appropriate safety practices.
- Rendering first aid.



attention

During startup no button on the front panel must be pressed

Technical data

indication:	LC-Display, 2 lines with 16 signs
nominal voltage:	230 VAC ($\pm 10\%$) 115 VAC (optional) 24 VDC (optional)
frequency range:	50 Hz $\pm 10\%$
nominal current:	65 mA @230/115V 50Hz 500 mA @24 VDC
nominal power	15 VA @230/115V 50Hz 12 VA @24 VDC
maximum main interference:	150 V/20 ms, followed by automatic RESET by integrated monitoring module with backup of the count
EMV tests:	according to EN 55011/ 55011-A1; EN 61326-1/ 61326-A1 and EN 50082-1/2
Functional test:	Watchdog, FAIL function with drop-out contact in the event of fault
Available auxiliary power:	24 VDC/160 mA for transmitter supply (with auxiliary power 115/230 VAC only) No transmitter supply is possible with auxiliary power 24 V DC
analog inputs:	6x 0/4-20 mA switchable via software 2x switchable to Pt100 direct input measuring range for Pt100: $-200^{\circ}\text{C} \dots +500^{\circ}\text{C}$
Analog/Digital converter	Internal resistance 24 Ohm per current input, $>10 \text{ M}\Omega$ for Pt100 14 bit resolution with integrated 50Hz-suppression; complete electrical isolation from the computer and all outputs(except in the case of transmitter supply))
Frequency input:	0,1 up to 10kHz
Analog outputs:	1x 0/4-20 mA, optional 2x 0/4-20 mA max. load: 500 Ohm
count pulse:	max. 1W, max 30 V
resolution of the outputs:	14 bits, completely electrically isolated from the computer and all inputs
relay outputs:	2x free configurable, 1x Fail-relay max. load of the contacts: 250VAC/8A



***Caution:** Before installation and operation customer has to check the nominal voltage. Only the declaration on the type plate is guilty!

Dimensions

enclosure:	glass-fibre-reinforced Noryl, front panel $144 \times 72 \text{ mm}^2$ (DIN)
material:	Noryl SE1 GFN2
protection class:	IP 20 (enclosure); IP64 (display unit)
depth:	ca. 170 mm
panel cut-out:	5.45" x 2.7" ($138 \times 68 \text{ mm}^2$)

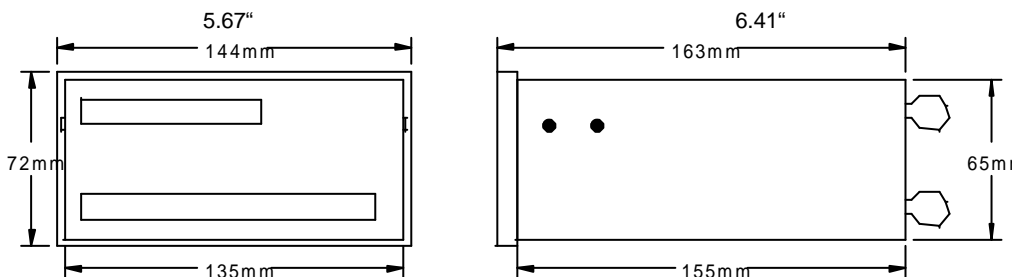

Mechanical mounting

The standard μ flow is a panel mounting unit. After preparing the panel cut-out, customer has to mount the μ Flow while using the delivered mounting brackets. Please pay attention to use the delivered seal between panel and μ Flow-housing.

Cleaning

The μ Flow has to be cleaned only with a dry daster.

General hints for Electrical connection



Signal leads must be shielded, one end of the shield has to be connected to mass. Signal and main leads have to be layed seperately.

For electrical installation following determinations are to be observed:

- power supply wiring has to be designed for nominal current
- power supply has to be installed, so that the power supply of μ Flow can be switched off
- switch off power supply before opening the μ Flow .

Connection examples for inputs

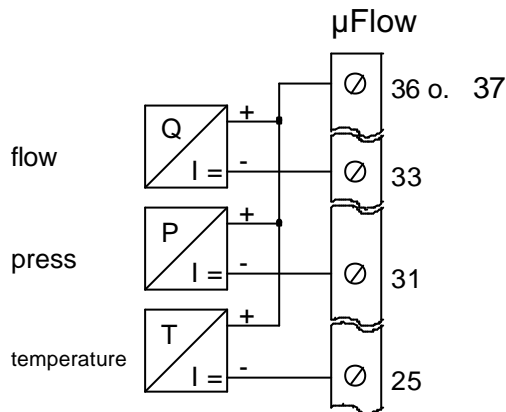

picture 1: passive current inputs, the μ Flow powers the transmitters

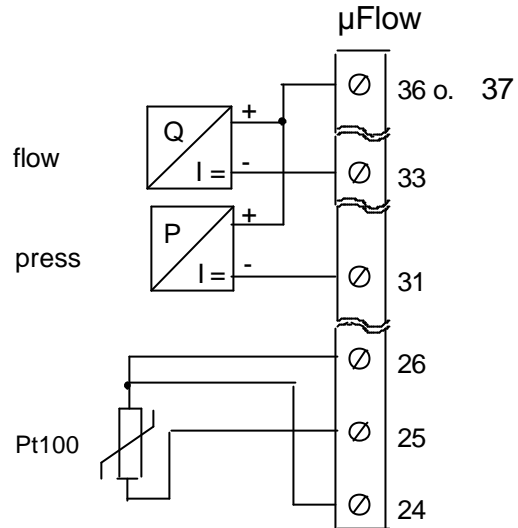

picture 2: passive current inputs, with Pt100 direct connection instead of using a temperature transmitter

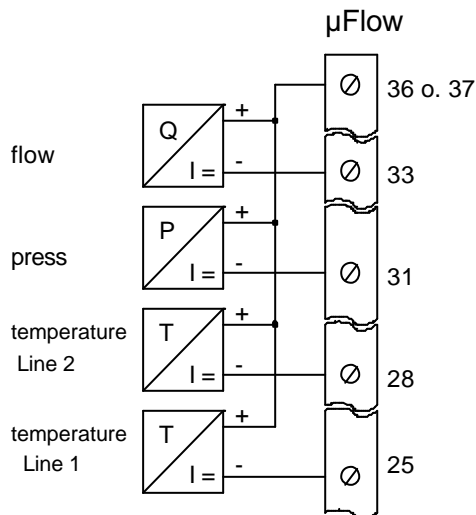

picture 3: passive current inputs with temperature in both lines

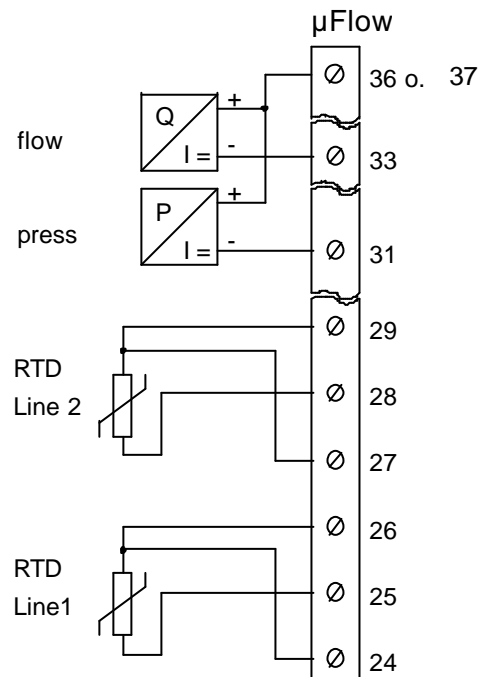

Picture 4: passive current inputs with temperature . RTD elements directly connected to the μ FLOW.

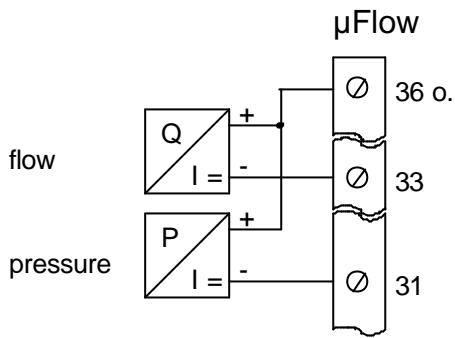

picture 5: measuring of saturated steam with pressure measurement

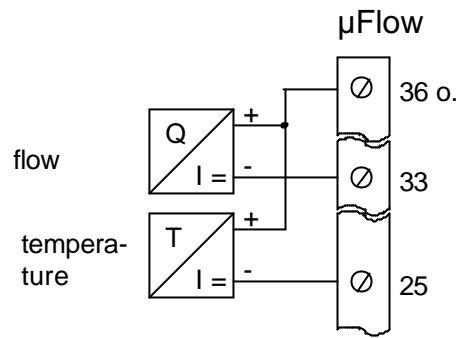

picture 6: measuring of saturated steam with temperature measurement

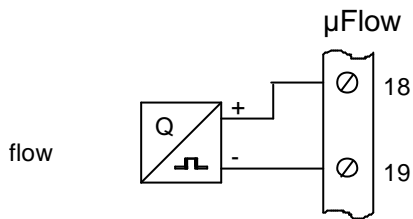

picture 7: frequency input for the flow signal

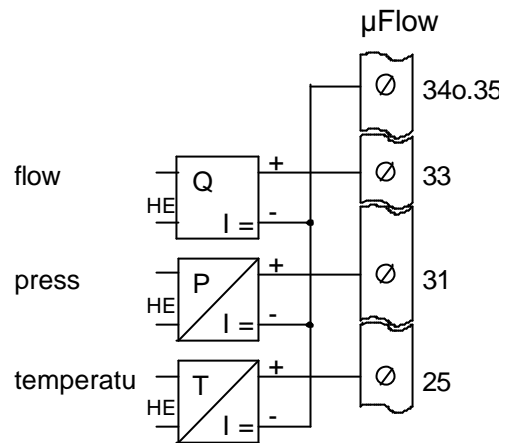

Picture 8: active signals, the transmitters are powered by an external supply. HE = auxiliary power

Connection examples for the output

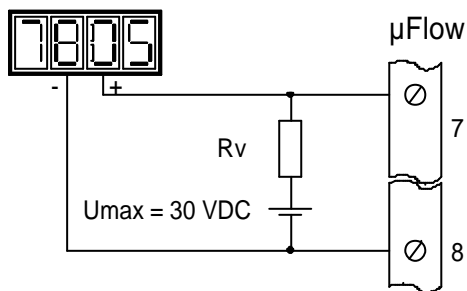

picture 9: external counter with voltage input. The series resistor R_v should be used in a range of 1 to 10 $k\Omega$.

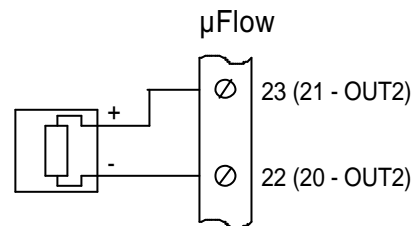

picture 10: analog output, outputs are active, there is no need for an external power supply. The max. load is 500 Ω

The terminals in detail

Long terminal row

terminal	name	use
1	L/DC+	Power supply, (24 V DC + optional)
2	N/DC-	Power supply, (24 V DC - optional)
3	PE	mass
4	RXD	Transmit Data
	TXD	Receive Data
6	DGND	Data Ground
7	CNT	Pulse output NPN Open collector
8	DGND	GND for pulse output
9	CO	Relay 1
10	NO	
11	NC	
12	CO	Relay 2
13	NO	
14	NC	
15	CO	Fail-Relay
16	NO	
17	NC	
18	Freq+	Frequency input
19	Freq-	
20	OUT2-	Analog output 2 (Option)
21	OUT2+	
22	OUT1-	Analog output 1
23	OUT1+	

short terminal row

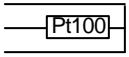
terminal	name	use
24	B	Current input T1 or 
25	A/IN5	
26	b	
27	B	Not used
28	A/IN6	
29	b	
30	IN4	Not used
31	IN3	Current input pressure
32	IN2	Current input Flow 2
33	IN1	Current input Flow 1
34	GND	GND for transmitters
35	GND	GND for transmitters
36	24V	Auxiliary power for transmitters
37	24V	Auxiliary power for transmitters

hint

When selecting a frequency generator, attention must be paid to the correct setting of the Jumpers located inside the unit behind the FREQ input terminals.. The Jumpers are set to TTL/CMOS inputs at the works unless otherwise specified in the parameterization log. The following table shows the correct Jumper settings.

signal type	Jumper (gemäß Draufsicht)							
	1	2	3	4	5	6	7	8
TTL, CMOS, pulse	x	x	0	0	0	1	1	0
pulse with log.0 above 1,4V	x	x	0	0	0	0	1	0
pulse with log.0 below 0,2V	x	x	0	0	1	0	1	0
open Collector NPN	x	x	1	0	0	0	1	0
open Collector PNP	x	x	0	0	0	0	1	1
Coil (high impedance)	x	x	0	1	0	0	0	0
Coil (low impedance)	x	x	0	1	0	0	0	1

x = don't care
1 = Jumper
0 = no Jumper

Jumper for frequency inputs

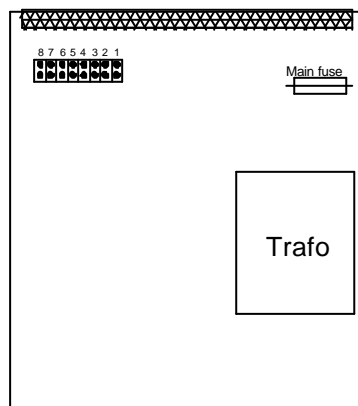

Picture 11: main circuit board with Jumpers for the frequency input

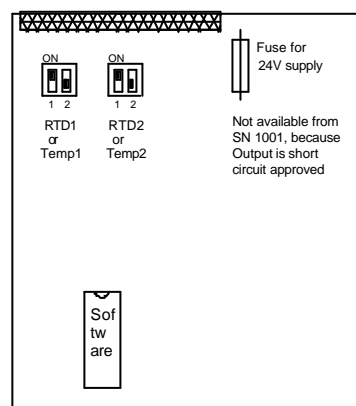

picture 12: CPU circuit board with the DIP-switches for the temperature inputs

Choosing the signal for the temperature input (Pt100 or current)

Picture 12 shows the location of the DIP switches for the adjustment of the temperature inputs. The switches are reachable after dismounting of the back panel

switch	1	2
Pt100	off	on
current	on	off

Exchange of the fuses

The main fuse is located on the main circuit board (see picture 11). The fuse for the 24 V auxiliary power is located on the CPU circuit board (see picture 11). The fuses are reachable after dismounting of the back panel. The type of fuse to be used is depending on the power supply

Power supply	Main fuse	Fuse for 24V
230V AC	250V/80 mAT	250V/160 mAT
115V AC	250V/80mAT	250V/160 mAT
24V DC	250V/0,5 AT	-

The displays

During startup the calculator indicates a message as „prozess: 0“, the meaning of this message is as follows:

Prozess: 1 = saturated steam with temperature measurement (Sattd1)
 Prozess: 2 = saturated steam with pressure measurement (Sattd2)
 Prozess: 3 = super heated steam
 Prozess: 4 = water

The following table show the different displays. By pressing the "↓" key, it is possible to switch between the displays in descending order of the table. By pressing the "↑" key, it is possible to switch in the opposite direction. After pressing the SELECT key, the TAG-no., which can be programmed by the user, will be indicated. After pressing the SELECT key again, you get back to the normal display mode.

Indication of heat and temperature of line 1 and 2

```

q̇ = 0 kW
tv=0.0°C  tr=0.0°C
  
```

Indication of heat and energy

```

q̇ = 0 kW
Q = 0 kWh
  
```

Indication of mass flow, temperature 1 and pressure

```

ṀV= 0.0 kg/h
tv=0.0°C  P=0.00kPa
  
```

Indication of heat, temperature 1 and pressure

```

q̇ = 0.0 kW
tv=0.0°C  P=0.00kPa
  
```

Totalized mass and energy

```

ΣMV= 0 kg
Q = 0 kWh
  
```

Flow rate and status of Relay 1 + 2

```

Q = 0.0 m³/h
A1=NORM  A2=NORM
  
```

Totalized flow and energy

```

ΣV= 0 m³
Q = 0 kWh
  
```

Indication of specific density und entalphy in both lines

These two indications are interchanging automatically

```

vv= 0.0 m³/kg
hv= 0.0 kJ/kg
vr= 0.0 m³/kg
hr= 0.0 kJ/kg
  
```

These two indications only appear, if the access is set to Laboratory, OEM or Factory eingestellt

```

f = 0.00 Hz
wstf = 0.00 nix
SELECT drücken>
DMM-Modus
  
```

Menu tree

attention: For some parts of the menu the access is denied.

Level	A	B	C	D	Input / indication	comments
1	Info	Version			WT-1.9917ff	Indication of the software version, no input possible
2		Ser.No.			SN: XXXX	Indication of the serial number, no input possible
3	Params	Flow1	dp	dp1.min	Input of dP-value for 0/4mA	Does not appear, if a velocity sensor is chosen
4				dp1.max	Input of dP-value for 20mA	
5				dp2.min	Input of dP-value for 0/4mA	Attention: if no second dp- transmitter is connected, the values for dp2.min + dp2.max must be set to zero
6				dp2.max	Input of dP-value for 20 mA	
7				k-factor	Input of value	Specification of the k-factor
8			velocity	Puls/V	Input of value	Does not appear, if a dp-sensor is chosen
9				Vmin	Input of value	Zero point in m³/h
10				Vmax	Input of value	span in m³/h
11			Pipe- ID		Input of value	Internal pipe diameter
12			Schleich		Input of value	cutoff in %
13			%Wetstm		Input of value	
14	Temp1	T1.min			temperature according to 0/4mA	Does not appear for Sat.st2 and for RTD-Direct-input
15		T1.max			temperature according to 20mA	
16	Temp2	T2.min			temperature according to 0/4mA	Appears only, if "1" is chosen in the Menu RETRN
17		T2.max			temperature according to 20mA	
18	press1	p.min			Pressure according to 0/4 mA	Only appears for Sat.st2, superheated steam und water
19		p.max			Pressure according to 20 mA	
20	Signal	Damping			Input of value	
21		Timebas			Hours, minutes, seconds,	choosing the timebase
22		UNIT	m.form		kg, t, lbs	Choosing the unit for mass flow in line1
23			m.backw		kg, t, lbs	Choosing the unit for mass flow in line 2
24			*Σm.forw		kg, t, kt	Choosing the unit for total mass in line 1
26			*Σm.back		kg, t, kt	Choosing the unit for total mass in line 2
27			*ΣV		m³, l	Choosing the unit for the totalized flow
28			t		°C, K	Unit for temperature
29			p		bar, kPa, hPa, psi	Unit for pressure
30			Q.		kW, MW	Unit for heat
31			Q		kJ, MJ, kWh, MWh	Unit for energy
32		NKS			0NKS, 1NKS	Digits after the decimal point
33	Outputs	Relay1	fnction		V.act, m.vorw, m.back, Q.forw, Q.backw, Q.total, t.forw, t.backw, p	Function of Relay
34			Charakt		Water, Supply, min, max	Characteristic of Relay
35			value		Input of value	
36		Relay2	fnction		V.act, m.vorw, m.back, Q.forw, Q.backw, Q.total, t.forw, t.backw, p	Function of Relay
37			Charakt		Water, Supply, min, max	Characteristic of Relay
38			value		Input of value	
39		Analog1	fnction		V.act, m.forw, m.back, Q.forw, Q.backw, Q.total, t.forw, t.backw, p	Function of analog output
40			Charact		4-20, 0-20	Current characteristic
41			Lo-Val		Input of value	Value for 0/4 mA

Level	A	B	C	D	Input / indication	comments
42				Hi-VAL	Input of value	Value for 20 mA
43			Analog2	fnction	V.act, m.forw, m.back, Q.forw, Q.backw, Q.total, t.forw, t.backw, p	Function of analog output
45				Charact	4-20, 0-20	Current characteristic
46				Lo-Val	Input of value	Value for 0/4 mA
47				Hi-VAL	Input of value	Value for 20 mA
48			cntpuls	Charact	Σ m.forw, Q.total, V	Characteristic of the countpulse
49				Pulswid	10ms, 50ms, 100ms	Pulse width
50				Scale	1000:1, 100:1, 10:1, 1:1, 1:10, 1:100, 1:1000	Scale of pulse
51			RS232	Cycle	Input of value	
52				Baud	4800, 9600	Baudrate
53		Tag.No.			Input of signs	Specification of TAG-No
54	calibr	inputs	IN1	Lo-VAL	Connect 4mA to input, press ENTER o.Reset	Calibration of current input 1 low value
55				Hi-VAL	Connect 20mA to input, press ENTER o.Reset	Calibration of current input 1 high value
56			IN2	see IN1	see IN1	see IN1
57			IN3	see IN1	see IN1	see IN1
58			IN4	see IN1	see IN1	see IN1
59			IN5	see IN1	see IN1	see IN1
60			IN6	see IN1	see IN1	see IN1
61			RTD1	LO-VAL	Connect 0 Ω to input, press ENTER o.Reset	Calibration or Pt100 input low value
62				HI-VAL	Connect 330 Ω to input, press ENTER o.Reset	Calibration or Pt100 input high value
63			RTD2	see RTD 1	see RTD 1	
64		outputs	OUT1	DAU-LO	adjustment: 4,0 mA	Output calibration for 4 mA
65				DAU-HI	adjustment: 20,0 mA	Output calibration for 20 mA
66			OUT2	see OUT1	see OUT1	
67	Config	Remote			Remote Control	To leave remote control press the RESET keys
68		Usenam			Input of value	Input of a username by using the arrow keys
69		Languag			Deutsch, English	Choose language
70		retrn			Input of value	Choosing the structure of temp .inputs
71		Struct	Sensors		Input of value	Choosing the sensor structure
72			P.Envir		Input of value	Atmospheric pressure in kPa
73			In-Levl		Input of value	Choosing 0- or 4-20 mA inputs
74		Process			Sat.st1, Sat.st2, Suph.st, Water	Choosing the calculation basis
75		Reset			SW-Res, HW-Res, both, none	Reset of parametrisation and/or Structure ! ATTENTION ! new calibration and parametrisation required
76		Acc_Cnt			N.o.acc.: 21	Account counter
77	Factory	SERIAL.			Input of value	Serial number
78		Access			Reset of account counter	
79		HW-Byte			Input of value	Selecting the outputs
80		Name			Input of signs	Startup message
81	Σ -Reset					Reset of summators
82	Access	ID-No.			Input of value	Choosing the access
83		Level			list	Choosing the access
84	Measure					Back to normal operation

* internal summators do not have a run over, that means that depending on configuration the value of the counter can be so high, that it is not possible to indicate the unit and the formula sign. For this reason it is necessary to reset the summators in time.

Short example for changing parameter value

It is necessary for you to change the value of temperature for 20 mA. Follow the short instruction below:

Press simultaneously both PROG-keys. If flow computer has a password, you have to set ID-no.. Programm „2552“. Now you allowed to change most of all menu points (see table below „Access“). Now press →-key. „PARAMS“ is indicated on the left side of display. Press SELECT-key. Press →-key as long as „TEMP1“ is shown on left side of display. Press SELECT-key. Press →-key as long as you can read „TEMP1,max“ on left side of display. Press SELECT-key. Now you can change value of temperature while using ← -, ↑-, → - and ↓ -key. Finish parameter setting while pressing SELECT-key. Press →-key as long as „ENDE“ is shown on left side of display. Press SELECT-key. Press →-key as long as „MEASURE“ is shown on the side of display. Press SELECT-key. Now the flow computer save parameter changing and starts measuring mode. If you want to protect parameter mode press both PROG-keys. Then press →-key as long as „ACCESS“ is shown on the left side of display. Press SELECT-key. Press one time →-key. Now „LEVEL“ is indicated. Press SELECT-key. Now „locked“ is shown on the left side of display. Now press SELECT-key. Go to menu-point END and then MEASURE to leave parameter mode. Now the flow computer is protected to not authorized programming.



warning: RESET-keys are only in use for factory setting

Access

The following table shows the most important ID-codes with the available parts of the menu.

Code Menu	0000	1508	2552	xxxx	xxxx	xxxx
	blocked	worker	Eng.	Labor.	OEM	Factory
INFO		x	x	x	x	x
PARAMS			x	x	x	x
CALIBRG				x	x	x
CONFIG					x	x
FACTORY						x
Σ-RESET		x	x	x	x	x
ACCESS		x	x	x	x	x
MEASURE		x	x	x	x	x

Water alarm – menu point %Wetstm (level C/13)

This menu point is only valid for superheated steam applications

Due to the accuracy ranges of the sensors and transmitters it is possible the in the near of the saturation point an water alarm can occur although the medium is still steam. With the here chosen value (0.50), the user can decide how much the measured pressure is allowed to be above the pressure at the saturation point before a water alarm occurs. Within this range the μFLOW interpretes the steam as saturated. The temperature measurement is ignored.

Sensorbyte – menu point SENSORS (Level C/65)

The sensorbyte indicates, which inputs are available and how they can be used. The following table should enable you to choose the correct sensorbyte.

inputs	critierium: 0	critierium 1	choose 0 or 1	Bit	
temperature 1	Transmitter	PT 100	0	1	0
Temperature 2	Transmitter	PT 100	0	2	0
pressure	Gauge pressure	abs pressure	1	4	4
Flow input 1 kind of sensor	velocity	dp	1	8	8
Flow input 1 signal	rad/current	lin/frequency	0	16	0
Flow input 2 kind of sensor	velocity	dp	0	32	0
Flow input 2 signal	rad/current	lin/frequency	0	64	0
Sensorbyte =					12

k-Factor – Menu point k-factor (level D/7)

By using an averaging pitot tube, the k-factor of the dp-sensor can be taken from the differential pressure calculation sheet. For unknown k-factors the value can be calculated by using the following equation.

The equation for mass flow is:
$$k = \frac{25 \cdot \dot{m}}{D_i^2 \cdot \sqrt{\Delta p} \cdot r}$$

Used units:

$\left[\dot{m} \right] = \frac{kg}{h}$	Mass flow
$[D_i] = mm$	Internal pipe diameter
$[\Delta p] = mbar$	Full scale differential pressure
$[r] = \frac{kg}{m^3}$	Density of the medium under operation conditions

The transfer characteristic

A square rooted or a linear characteristic can be chosen. The μ FLOW offers the possibility to link a second differential pressure transmitter for the extension of the measuring range by measuring point switching. Under the menu options dp.min. and dp.max. the measuring range boundaries for this second transmitter can be indicated in the same way as it is already described above for the first transmitter.

Application of the RS232 Interface

The RS232 interface supports datalogging.

Link and control of the μ FLOW with a PC

The connection between μ FLOW and PC is made by a three-core cable with max. 10 m length. The TxD clamp at the μ FLOW is to be connected with the RxD line at the PC interface and the RxD clamp at the μ FLOW with the TxD line of the PC.

The terminal software of the selected COM interface should be adjusted to operation without protocol or with XON / XOFF protocol. Only if a hardware protocol is intended, the appropriate handshake lines at the serial interface are to be short circuited.

Adjusting the Baudrate - menu option BAUD (level D/46)

Possible are 4800 and 9600 Baud.

Adjusting the duration of the transmission cycle

- menu option CYCLE (level D/45)

The transmission cycle influences directly the developing data flood. Since it concerns with currents in all rule slow processes, the quantity of data which can be stored should be reduced to a meaningful measure. The μ FLOW therefore supports a minimum interval of 5 seconds.

Parameters

According to the transfer parameters selected in the very most applications the μ FLOW transmits with

- 8 data bits
- 1 stop bit
- without parity
- with XON / XOFF log

The Baudrate as well as the time between two transfers are adjustable, other parameters are not adjustable.

Protocol

Due to the low absolute transfer rates it should not come to any conflict in the communication between μ FLOW and PC. Therefore a protocol is actually unnecessary. Nevertheless the transmission activity of the μ FLOW can be controlled by transmitting XOFF by the PC and be continued with XON afterwards again for all cases. If the interruption should last longer than a transmission cycle, then the data resulting in the meantime are ignored.

Data format

The μ FLOW transmits text character sequences (ASCII) with information about the momentary flow, the status of the totalizer as well as the primary status data pressure and temperature. The individual values are separated by blank (ASCII code 32).

A typical line read from left to right could look as follows:

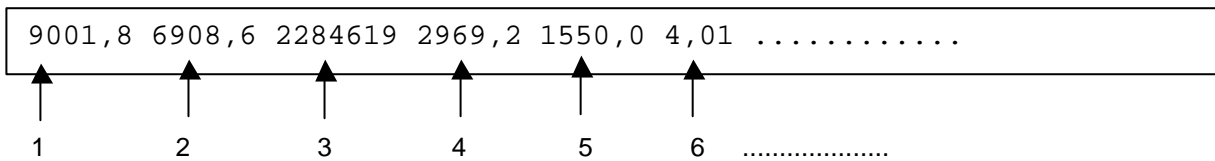

1. actual value of the massflow (upstream) in adjusted unit
2. actual value of the massflow (downstream) in adjusted unit
3. actual value auf total heat in adjusted unit
4. actual value auf upstream heat in adjusted unit
5. actual value auf downstream heat in adjusted unit
6. totalized value of the heat in adjusted unit
7. totalized value of the upstream massflow in adjusted unit
8. totalized value of the downstream massflow in adjusted unit
9. totalized value of the volumeflow in adjusted unit
10. upstream temperature in adjusted unit
11. downstream temperature in adjusted unit
12. actual volume flow in adjusted unit
13. upstream pressure in adjusted unit
14. (downstream pressure in adjusted unit)

The entry and the processing of the measuring data is made according to the standard of the used hard- and software on the PC.

Trouble shooting

Description of the failure	Possible reason
No indication on th display	Auxiliary power is missing Main fuse is defective (see page 8)
Instrument does not react on the current inputs	Sensorbyte chosen wrong (see page 12)
Instrument does not react on the frequency input	Sensorbyte chosen wrong (see page 12) Setting of the jumper does not fit to the signal (see page 6)
Instrument does not react on the Pt100 input	Sensorbyte chosen wrong (see page 12) DIP-switches in wrong position (see page 8)
Auxiliary power for the sensors is missing	Fuse for 24VDC defective (see page 8) There is no fuse from SN1001 External short circuit
Indicated measured and calculated values are not realistic	Wrong parametrisation
Output current wrong	Wrong structure 0..20 mA instead of 4..20 mA or the other way round Zero or span value wrong
„water“ is indicated in the display	Calculator is configured for superheated steam, but according to measured values for temperature and pressure the medium is water. The reason could be a defective sensor or transmitter
The indication for temperature is „1255“ or t over	RTD defective or wrong connected to the μ FLOW Wrong adjustment of the DIP -

Of course this listing can not be complete. If any mistake occurs, which is not described here, please do not hesitate to contact us.

EC-Declaration of Conformity
according to Article 10.1 of the Directive 89/336/EEC
(EMC-Directive)

We,

S.K.I. Schlegel & Kremer Industrieautomation GmbH,
Dorfbroicher Str. 53-55, 41236 Mönchengladbach

declare in the whole responsibility that the product:

Sensor Unit

Product

µFLOW

Type designation and (if necessary) serial number

observes the principal protection requirements determined in the Council Directive for the adoption of the legal regulations of the Member States about electromagnetic compatibility (89/336/EEC and his amendments 92/31/EEC & 93/68/EEC).

The judgement of the product as to electromagnetic compatibility was effected on the basis of the following standards:

- **EMISSION**

EN 55011: 1998 + A 1: 1999 – Limit Class A

(Limits and methods of measurement of radio disturbance characteristics of industrial, scientific and medical (ISM) radio-frequency equipment)

- **IMMUNITY**

EN 61326-1: 1997 + A1: 1998

(Electrical equipment for measurement, control and laboratory use EMC requirements – Part 1 General requirements)

EN 50082-2: 1995

(Electromagnetic compatibility (EMC), Generic Immunity Standard, Part 2: Industrial environment)

Following operating conditions and/or operating ambients are granted:

- **Using of the product in residential and industrial areas –**

This declaration based on:

The above mentioned standards are harmonized and published into the official journal of the EC Nbr. 2001/C105



Friedhelm Kremer
General Manager

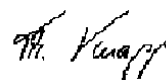

Thomas Knapp
Quality Management

05.11.2001

S.K.I. Schlegel & Kremer Industrieautomation GmbH; Dorfbroicher Str. 53-55; 41236 Mönchengladbach