



μFLOW 100GAS

compact calculator for gas applications

Instruction manual

July 2001

Valid from software version GS 1.9917

Ufg005-04.doc

S.K.I Schlegel & Kremer Industrieautomation GmbH
Gerberstr. 49 - 41199 Mönchengladbach
phone: ++49/2166/62317-0 - fax: ++49/2166/611681

doc.-no.: BA-Ufg005-04.doc

content

Explanations of symbols	3
General Hints	3
Qualified Personnel	3
Technical data	4
Dimensions	4
Mechanical mounting	4
Cleaning	5
General hints for Electrical connection	5
Connection examples for inputs	5
Connection examples for the output	6
The terminals in detail	6
Choosing the signal for the temperature input (Pt100 or current)	7
Exchange of the fuses	7
The displays	8
Menu tree	9
Short example for changing parameter value	11
Access	11
Sensorbyte – menu point SENSORS (Level C/65)	11
k-Factor – Menu point k-factor (level D/7)	12
The transfer characteristic	12
Application of the RS232 Interface	12
Link and control of the μ FLOW with a PC	12
Adjusting the Baudrate - menu option BAUD (level D/46)	12
Adjusting the duration of the transmission cycle	12
Parameters	12
Protocol	13
Data format	13
Trouble shooting	14
Description of the failure	14
Possible reason	14
EC-Declaration of Conformity	15

Explanations of symbols



Warning of a danger place (caution: consider documentation)
ISO 3864, No. B.3.1



Warning of dangerous electrical voltage
ISO 3864, No. B.3.6

General Hints

For reasons of clarity this manual does not contain detailed information about all types of products and cannot take into account every conceivable case of installation, operation or maintenance.

If you require further information or should problems occur which are not sufficiently explained in the manual, you can consult us directly to obtain the necessary information.

	CAUTION
	<p>This equipment is a Limit Class A once. It can cause radio disturbance in residential. On this case customer has to take care appropriate measure.</p> <p>This equipment should only be installed and operated after qualified personnel have ensured that suitable power supply (see name plate) will be used and that during normal operation or in case of a defect in the system or in components no hazardous situation can occur. Therefore serious injuries and/or considerable material damage cannot be ruled out in the event of improper handling of the device.</p> <p>The perfect and safe operation of this equipment is conditional upon proper transport, proper storage, installation and assembly as well as on careful operation and commissioning.</p>

May we also draw your attention to the fact that the contents of the manual are not part of a previous or existing agreement, approval or legal relationship or an amendment thereof. All obligations of the S.K.I. GmbH result from the contract of purchase which also contains the full and solely valid warranty agreement. These contractual warranty conditions are neither extended nor restricted by the contents of the manual.

Qualified Personnel

are persons familiar with the installation, assembly, commissioning and operation of the product and who have the appropriate qualifications for their activities such as:



- Training or instruction or authorization to operate and maintain devices/systems according to the standard of safety technology for electrical installations.
- Training or instruction in the proper care and use of protective equipment in accordance with appropriate safety practices.
- Rendering first aid.



attention

During startup no button on the front panel must be pressed

Technical data

indication:	LC-Display, 2 lines with 16 signs
nominal voltage:	230 VAC ($\pm 10\%$) 115 VAC (optional) 24 VDC (optional)
frequency range:	50 Hz $\pm 10\%$
nominal current:	65 mA @230/115V 50Hz 500 mA @24 VDC
nominal power	15 VA @230/115V 50Hz 12 VA @24 VDC
maximum main interference:	150 V/20 ms, followed by automatic RESET by integrated monitoring module with backup of the count
EMV tests:	according to EN 55011/ 55011-A1; EN 61326-1/ 61326-A1 and EN 50082-1/2
Functional test:	Watchdog, FAIL function with drop-out contact in the event of fault
Available auxiliary power:	24 VDC/160 mA for transmitter supply (with auxiliary power 115/230 VAC only) No transmitter supply is possible with auxiliary power 24 V DC
analog inputs:	6x 0/4-20 mA switchable via software 2x switchable to Pt100 direct input measuring range for Pt100: $-200^{\circ}\text{C} \dots +500^{\circ}\text{C}$
Analog/Digital converter	Internal resistance 24 Ohm per current input, $>10 \text{ M}\Omega$ for Pt100 14 bit resolution with integrated 50Hz-suppression; complete electrical isolation from the computer and all outputs(except in the case of transmitter supply))
Frequency input:	0,1 up to 10kHz
Analog outputs:	1x 0/4-20 mA, optional 2x 0/4-20 mA max. load: 500 Ohm
count pulse:	max. 1W, max 30 V
resolution of the outputs:	14 bits, completely electrically isolated from the computer and all inputs
relay outputs:	2x free configurable, 1x Fail-relay max. load of the contacts: 250VAC/8A



*** Caution:** Before installation and operation customer has to check the nominal voltage. Only the declaration on the type plate is guilty!

Dimensions

enclosure:	glass-fibre-reinforced Noryl, front panel $144 \times 72 \text{ mm}^2$ (DIN)
material:	Noryl SE1 GFN2
protection class:	IP 20 (enclosure); IP64 (display unit)
depth:	ca. 170 mm
panel cut-out:	$5.45'' \times 2.7''$ ($138 \times 68 \text{ mm}^2$)

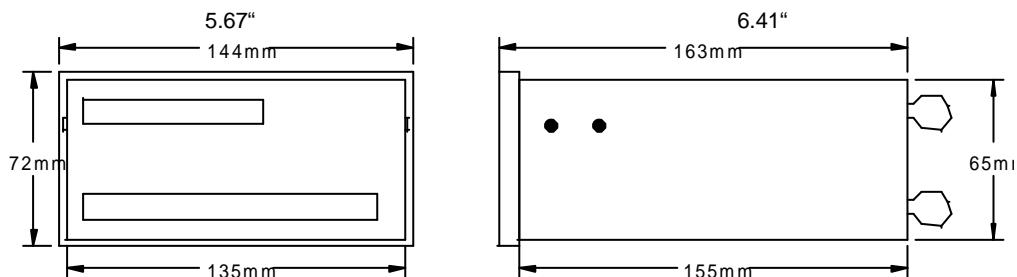

Mechanical mounting

The standard μ flow is a panel mounting unit. After preparing the panel cut-out, customer has to mount the μ Flow while using the delivered mounting brackets. Please pay attention to use the delivered seal between panel and μ Flow-housing.

Cleaning

The μ Flow has to be cleaned only with a dry daster.

General hints for Electrical connection



Signal leads must be shielded, one end of the shield has to be connected to mass. Signal and main leads have to be layed seperately.

For electrical installation following determinations are to be observed:

- power supply wiring has to be designed for nominal current
- power supply has to be installed, so that the power supply of μ Flow can be switched off
- switch off power supply before opening the μ Flow

Connection examples for inputs



Bild 1: passive current inputs, the μ Flow powers the transmitters



Bild 2: passive current inputs, with Pt100 direct connection instead of using a temperature transmitter

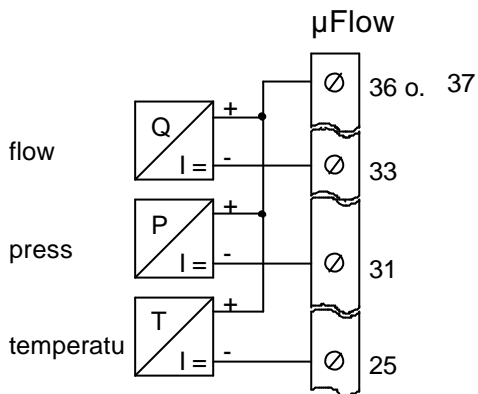

picture 3: without temperature measurement

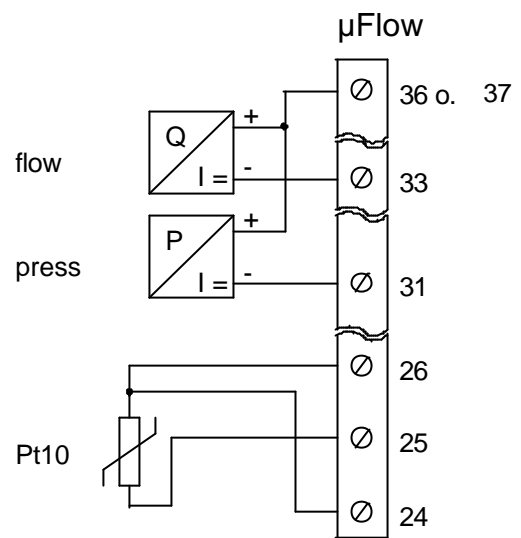
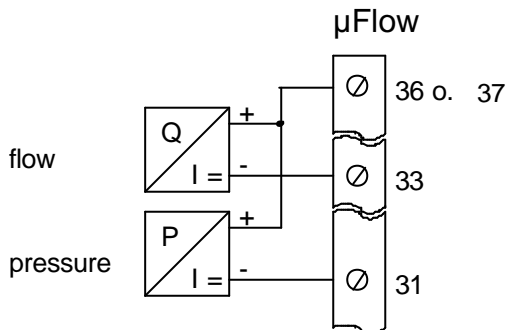
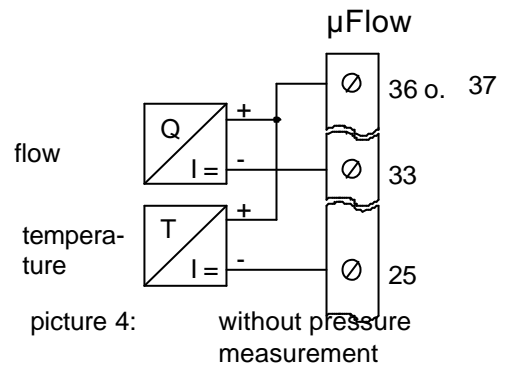

picture 4: without pressure measurement

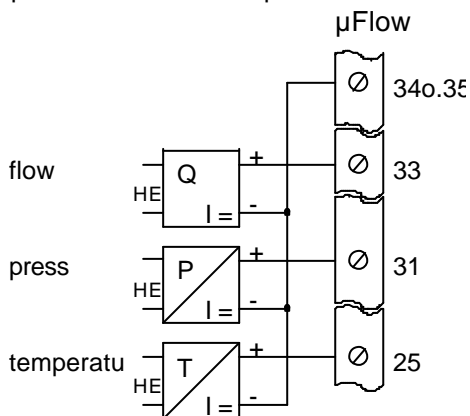

Picture 5: active signals, the transmitters are powered by an external supply. HE = auxiliary power

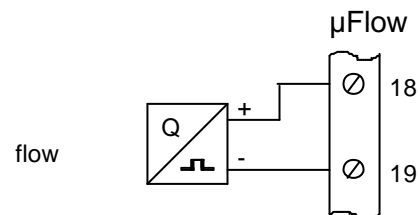

picture 6: frequency input for the flow signal

Connection examples for the output

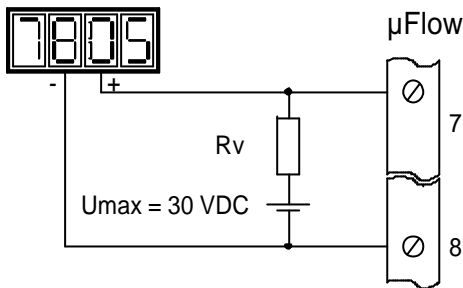

picture 7: external counter with voltage input. The series resistor R_v should be used in a range of 1 to 10 $k\Omega$.

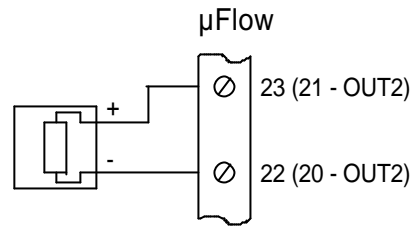

picture 8: analog output, outputs are active, there is no need for an external powersupply. The max. load is 500 Ω

The terminals in detail

Long terminal row

terminal	name	use
1	L/DC+	Power supply, (24 V DC + optional)
2	N/DC-	Power supply, (24 V DC - optional)
3	PE	mass
4	RXD	Transmit Data
	TXD	Receive Data
6	DGND	Data Ground
7	CNT	Pulse output NPN Open collector
8	DGND	GND for pulse output
9	CO	Relay 1
10	NO	
11	NC	
12	CO	Relay 2
13	NO	
14	NC	
15	CO	Fail-Relay
16	NO	
17	NC	
18	Freq+	Frequency input
19	Freq-	
20	OUT2-	Analog output 2 (Option)
21	OUT2+	
22	OUT1-	Analog output 1
23	OUT1+	

short terminal row

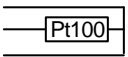
terminal	name	use
24	B	Current input T1 or 
25	A/IN5	
26	b	
27	B	Not used
28	A/IN6	
29	b	
30	IN4	Not used
31	IN3	Current input pressure
32	IN2	Current input Flow 2
33	IN1	Current input Flow 1
34	GND	GND for transmitters
35	GND	GND for transmitters
36	24V	Auxiliary power for transmitters
37	24V	Auxiliary power for transmitters

hint

When selecting a frequency generator, attention must be paid to the correct setting of the Jumpers located inside the unit behind the FREQ input terminals.. The Jumpers are set to TTL/CMOS inputs at the works unless otherwise specified in the parameterization log. The following table shows the correct Jumper settings.

signal type	Jumper (acc. to top view)							
	1	2	3	4	5	6	7	8
TTL, CMOS, pulse	x	x	0	0	0	1	1	0
pulse with log.0 above 1,4V	x	x	0	0	0	0	1	0
pulse with log.0 below 0,2V	x	x	0	0	1	0	1	0
open Collector NPN	x	x	1	0	0	0	1	0
open Collector PNP	x	x	0	0	0	0	1	1
Coil (high impedance)	x	x	0	1	0	0	0	0
Coil (low impedance)	x	x	0	1	0	0	0	1

x = don` t care
1 = Jumper
0 = no Jumper

Jumper for frequency inputs

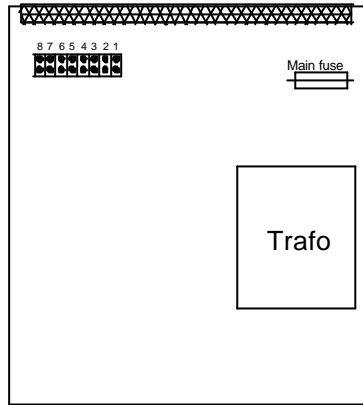

Picture 11: main circuit board with Jumpers for the frequency input

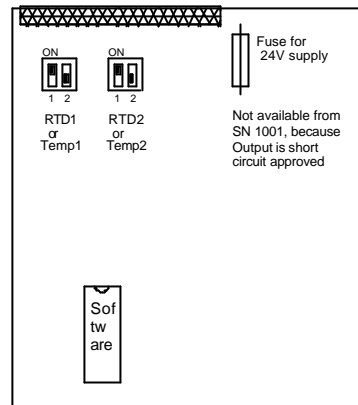

picture 12: CPU circuit board with the DIP-switches for the temperature inputs

Choosing the signal for the temperature input (Pt100 or current)

Picture 12 shows the location of the DIP switches for the adjustment of the temperature inputs. The switches are reachable after dismounting of the back panel

switch	1	2
Pt100	off	on
current	on	off

Exchange of the fuses

The main fuse is located on the main circuit board (see picture 11). The fuse for the 24 V auxiliary power is located on the CPU circuit board (see picture 11). The fuses are reachable after dismounting of the back panel. The type of fuse to be used is depending on the power supply

Power supply	Main fuse	Fuse for 24V
230V AC	250V/80 mAT	250V/160 mAT
115V AC	250V/80 mAT	250V/160 mAT
24V DC	250V/0,5 AT	-

The displays

The following table show the different displays. By pressing the "↓" key, it is possible to switch between the displays in descending order of the table. By pressing the "↑" key, it is possible to switch in the opposite direction. After pressing the SELECT key, the TAG-no., which can be programmed by the user, will be indicated. After pressing the SELECT key again, you get back to the normal display mode.

Standard volumetric flow
temperature and pressure

```
Qn=      0.0 m³/h
tv=0.0°C P=0.00kPa
```

Summator, standard volumetric flow
temperature and pressure

```
ΣU=      0 m³
tv=0.0°C P=0.00kPa
```

Standard volumetric flow and
Summator, standard volumetric flow

```
Qn=      0.0 m³/h
ΣU=      0 m³
```

Standard volumetric flow and
state of alarm contacts/relays

```
Qn=      0.0 m³/h
A1=NORM A2=NORM
```

Actual volumetric flow and
Standard volumetric flow

```
U =      0.0 m³/h
Qn=      0.0 m³/h
```

Compressibility and supercompressibility

```
Z=
Zn=
```

Flow velocity and
density of the medium

```
ω=
ρ=
```

Branching of subdisplays for value reading
only available with access for Laboratory, OEM
or Factory

```
SELECT drücken>
DMM-Modus
```

Menu tree

attention: For some parts of the menu the access is denied.

Level	A	B	C	D	Input / indication	comments
1	Info	Version			Ver. GAS-1.9917ff	Indication of the software version, no input possible
2		Ser.No..			SN:	Indication of the serial number, no input possible
3	Params	Flow1	dp	dp1.min	Input of dP-value for 0/4mA	Does not appear, if a velocity sensor is chosen
4				dp1.max	Input of dP-value for 20mA	
5				dp2.min	Input of dP-value for 0/4mA	Attention: if no second dp- transmitter is connected, the values for dp2.min + dp2.max must be set to zero
6				dp2.max	Input of dP-value for 20 mA	
7				k-factor	Input of value	Specification of the k-factor
8			density	density	Input of value	in kg/Nm ³
9		velocity	Puls/V	velocity	Input of value	Does not appear, if a dp-sensor is chosen
10				Vmin	Input of value	Zero point in m ³ /h
11				Vmax	Input of value	span in m ³ /h
12			Pipe-ID	Pipe-ID	Input of value	Internal pipe diameter
13			cutoff	cutoff	Input of value	cutoff in %
14	Temp	T1.min			temperature according to 0/4mA	
15		T1.max			temperature according to 20mA	
16	COMP 1	G1min			Input of value	in Vol. %
17		G1max			Input of value	in Vol. %
18	COMP 2	G2min			Input of value	in Vol. %
19		G2max			Input of value	in Vol. %
20	LIMIT				Input of value	in Vol. %
21	density	Rho1			Input of value	in kg/Nm ³
22		Rho2			Input of value	in kg/Nm ³
23		Rho3			Input of value	in kg/Nm ³
24	press	p.min			Pressure according to 0/4 mA	
25		p.max			Pressure according to 20 mA	
26	RG_DAT	CO2-CON			Input of value	in %
27		N2-CON			Input of value	in %
28		Ho,n			Input of value	in MJ/m ³
29		density			Input of value	in kg/Nm ³
30	Signal	Damping			Input of value	
31		Timebas			Hours, minutes, seconds,	choosing the timebase
32		UNIT	V _N		Nm ³ , NI	Unit for standard volumetric flow
33			*ΣV _N		Nm ³ , NI	Unit for summator of V _N
34			m		kg, t, lbs	Unit for mass flow
35			*Σm		Kg, t, kt	Unit for summator of m
36			t		°C, K, F	Unit for temperature
37			p		bar, kPa, hPa, psi	Unit for pressure
38	Outputs	Relay1	fncion		V _N , V.akt, m, t., p	Function of Relay
39			Charact		min, max	Characteristic of Relay
40			value		Input of value	
41		Relay2	fncion		V _N , V.akt, m, t., p	Function of Relay
42			Charact		min, max,	Characteristic of Relay
43			value		Input of value	
44		Analog1	fncion		V _N , V.akt, m, t., p	Function of analog output
45			Charact		4-20, 0-20	Current characteristic
46			Lo-Val		Input of value	Value for 0/4 mA

Level	A	B	C	D	Input / indication	comments
47				Hi-VAL	Input of value	Value for 20 mA
48			Analog2	fnction	$V_N, V_{akt}, m, t., p$	Function of analog output
49				Charact	4-20, 0-20	Current characteristic
50				Lo-Val	Wert eingeben	Value for 0/4 mA
51				Hi-VAL	Input of value	Value for 20 mA
52			cntpuls	Charact	$\Sigma m, \Sigma V_N$	Characteristic of the countpulse
53				Pulswid	10ms, 50ms, 100ms	Pulse width
54				Scale	1:1, 1:10, 1:100, 1:1000	Scale of pulse
55			RS232	Cycle	Input of value	
56				Baud	4800, 9600	Baudrate
57		Tag.No.			Input of signs	Specification of TAG-No
58	calibr	inputs	IN1	Lo-VAL	Connect 4mA to input, press ENTER o.Reset	Calibration of current input 1 low value
59				Hi-VAL	Connect 20mA to input, press ENTER o.Reset	Calibration of current input 1high value
60			IN2	see IN1	see IN1	see IN1
61			IN3	see IN1	see IN1	see IN1
62			IN4	see IN1	see IN1	see IN1
63			IN5	see IN1	see IN1	see IN1
64			IN6	see IN1	see IN1	see IN1
65			RTD1	LO-VAL	Connect 0 Ω to input, press ENTER o.Reset	Calibration or Pt100 input low value
66				HI-VAL	Connect 330 Ω to input, press ENTER o.Reset	Calibration or Pt100 input high value
67			RTD2	see RTD 1	see RTD 1	
68		outputs	OUT1	DAU-LO	adjustment: 4,0 mA	Output calibration for 4 mA
69				DAU-HI	adjustment: 20,0 mA	Output calibration for 20 mA
70			OUT2	see OUT1	see OUT1	
71	Config	Remote			Remote Control	To leave remote control press the RESET keys
72		Usenam			Input of value	Input of a username by using the arrow keys
73		Languag			Deutsch, English	Choose language
74		Struct	Sensors		Input of value	Choosing the sensor structure
75		Process			Ideal, AGA, Ethyl, Gaskomp	Calculation basis for the density
76		Reset			SW-Res, HW-Res, both, none	Reset of parametrisation and/or Structure ! ATTENTION ! new calibration and parametrisation required
77		Acc_Cnt			N.o.acc.: 21	Account counter
78		In-Byte			Input of value	Choosing inputs as 0..20 or 4..20 mA
79	Factory	SERIAL.			Input of value	Serial number
80		Access			Reset of account counter	
81		HW-Byte			Input of value	Selecting the outputs
82		Name			Input of signs	Startup message
83	Σ -Reset					Reset of summators
84	Access	ID-No.			Input of value	Choosing the access
85		Level			list	Choosing the access
86	Measure					Back to normal operation

* internal summators do not have a run over, that means that depending on configuration the value of the counter can be so high, that it is not possible to indicate the unit and the formula sign. For this reason it is necessary to reset the summators in time.

Short example for changing parameter value

It is necessary for you to change the value of temperature for 20 mA. Follow the short instruction below:

Press simultaneously both PROG-keys. If flow computer has a password, you have to set ID-no.. Programm „2552“. Now you allowed to change most of all menu points (see table below „Access“). Now press →-key. „PARAMS“ is indicated on the left side of display. Press SELECT-key. Press →-key as long as „TEMP1“ is shown on left side of display. Press SELECT-key. Press →-key as long as you can read „TEMP1,max“ on left side of display. Press SELECT-key. Now you can change value of temperature while using ← -, ↑-, → - and ↓ -key. Finish parameter setting while pressing SELECT-key. Press →-key as long as „ENDE“ is shown on left side of display. Press SELECT-key. Press →-key as long as „MEASURE“ is shown on the side of display. Press SELECT-key. Now the flow computer save parameter changing and starts measuring mode. If you want to protect parameter mode press both PROG-keys. Then press →-key as long as „ACCESS“ is shown on the left side of display. Press SELECT-key. Press one time →-key. Now „LEVEL“ is indicated. Press SELECT-key. Now „locked“ is shown on the left side of display. Now press SELECT-key. Go to menu-point END and then MEASURE to leave parameter mode. Now the flow computer is protected to not authorized programming.



warning: RESET-keys are only in use for factory setting

Access

The following tabel shows the most important ID-codes with the available parts of the menu.

Menu \ Code	0000	1508	2552	xxxx	xxxx	xxxx
	blocked	worker	Eng.	Labor.	OEM	Factory
INFO		x	x	x	x	x
PARAMS			x	x	x	x
CALIBRG				x	x	x
CONFIG					x	x
FACTORY						x
Σ-RESET		x	x	x	x	x
ACCESS		x	x	x	x	x
MEASURE		x	x	x	x	x

Sensorbyte – menu point SENSORS (Level C/65)

The sensorbyte indicates, which inputs are available and how they can be used.. The following table should enable you to choose the correct sensorbyte.

inputs	criterium: 0	criterium 1	choose 0 or 1	Bit	
temperature 1	Transmitter	PT 100	0	1	0
Temperature 2	Transmitter	PT 100	0	2	0
pressure	Gauge pressure	abs pressure	1	4	4
Flow input 1 kind of sensor	velocity	dp	1	8	8
Flow input 1 signal	rad/current	lin/frequency	0	16	0
Flow input 2 kind of sensor	velocity	dp	0	32	0
Flow input 2 signal	rad/current	lin/frequency	0	64	0
Sensorbyte =					12

k-Factor – Menu point k-factor (level D/7)

By using an averaging pitot tube, the k-factor of the dp-sensor can be taken from the differential pressure calculation sheet. For unknown k-factors the value can be calculated by using the following equation.

$$k = \sqrt{\frac{r_N * T_A}{\Delta p * p_A}} * \frac{15,23 * V_N}{D_i^2}$$

used units:

$[V_N] = \frac{Nm^3}{h}$	Standard volumetric flow	$[r_N] = \frac{kg}{Nm^3}$	Density at T=273,13K and p=101,325 kPa
$[D_i] = mm$	Internal diameter of the pipe	$[r] = \frac{kg}{m^3}$	Density under operation conditions
$[\Delta p] = mbar$	Full scale differential pressure	$[p_A] = kPa$	Design medium pressure
		$[T_A] = K$	Design medium temperature

The transfer characteristic

A square rooted or a linear characteristic can be chosen. The μ FLOW offers the possibility to link a second differential pressure transmitter for the extension of the measuring range by measuring point switching. Under the menu options dp.min. and dp.max. the measuring range boundaries for this second transmitter can be indicated in the same way as it is already described above for the first transmitter.

Application of the RS232 Interface

The RS232 interface supports datalogging.

Link and control of the μ FLOW with a PC

The connection between μ FLOW and PC is made by a three-core cable with max. 10 m length. The TxD clamp at the μ FLOW is to be connected with the RxD line at the PC interface and the RxD clamp at the μ FLOW with the TxD line of the PC.

The terminal software of the selected COM interface should be adjusted to operation without protocol or with XON / XOFF protocol. Only if a hardware protocol is intended, the appropriate handshake lines at the serial interface are to be short circuited.

Adjusting the Baudrate - menu option BAUD (level D/46)

Possible are 4800 and 9600 Baud.

Adjusting the duration of the transmission cycle

- menu option CYCLE (level D/45)

The transmission cycle influences directly the developing data flood. Since it concerns with currents in all rule slow processes, the quantity of data which can be stored should be reduced to a meaningful measure. The μ FLOW therefore supports a minimum interval of 5 seconds.

Parameters

According to the transfer parameters selected in the very most applications the μ FLOW transmits with

- 8 data bits
- 1 stop bit
- without parity
- with XON / XOFF log

The Baudrate as well as the time between two transfers are adjustable, other parameters are not adjustable.

Protocol

Due to the low absolute transfer rates it should not come to any conflict in the communication between μ FLOW and PC. Therefore a protocol is actually unnecessary. Nevertheless the transmission activity of the μ FLOW can be controlled by transmitting XOFF by the PC and be continued with XON afterwards again for all cases. If the interruption should last longer than a transmission cycle, then the data resulting in the meantime are ignored.

Data format

The μ FLOW transmits text character sequences (ASCII) with information about the momentary flow, the status of the totalizer as well as the primary status data pressure and temperature. The individual values are separated by blank (ASCII code 32).

A typical line read from left to right could look as follows:

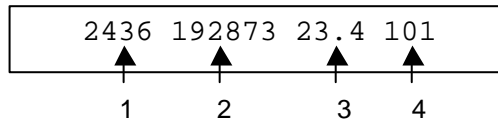

1. actual value of the flow in adjusted unit
2. totalizer in adjusted unit
3. temperature in adjusted unit
4. pressure in adjusted unit

The entry and the processing of the measuring data is made according to the standard of the used hard- and software on the PC.

EC-Declaration of Conformity
according to Article 10.1 of the Directive 89/336/EEC
(EMC-Directive)

We,

S.K.I. Schlegel & Kremer Industrieautomation GmbH,
Dorfbroicher Str. 53-55, 41236 Mönchengladbach

declare in the whole responsibility that the product:

Sensor Unit

Product

µFLOW

Type designation and (if necessary) serial number

observes the principal protection requirements determined in the Council Directive for the adoption of the legal regulations of the Member States about electromagnetic compatibility (89/336/EEC and his amendments 92/31/EEC & 93/68/EEC).

The judgement of the product as to electromagnetic compatibility was effected on the basis of the following standards:

- **EMISSION**

EN 55011: 1998 + A 1: 1999 – Limit Class A

(Limits and methods of measurement of radio disturbance characteristics of industrial, scientific and medical (ISM) radio-frequency equipment)

- **IMMUNITY**

EN 61326-1: 1997 + A1: 1998

(Electrical equipment for measurement, control and laboratory use EMC requirements – Part 1 General requirements)

EN 50082-2: 1995

(Electromagnetic compatibility (EMC), Generic Immunity Standard, Part 2: Industrial environment)

Following operating conditions and/or operating ambients are granted:

- **Using of the product in residential and industrial areas –**

This declaration based on:

The above mentioned standards are harmonized and published into the official journal of the EC Nbr. 2001/C105



Friedhelm Kremer
General Manager

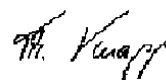

Thomas Knapp
Quality Management

05.11.2001

S.K.I. Schlegel & Kremer Industrieautomation GmbH; Dorfbroicher Str. 53-55; 41236 Mönchengladbach