

μFLOW GK2

**Compact computer
for gaseous media**

Operating instructions

S.K.I. Schlegel & Kremer Industrieautomation GmbH
Gerberstr. 49, 41199 Mönchengladbach - Germany
Telephone: ++49/2166/62317-0 - Telefax: ++49/2166/611681

Status: February 1998

Contents

1 APPLICATION AND OPERATION OF THE μFLOW GK2	3
1.1 THE μ FLOW AS GAS COMPENSATION COMPUTER.....	3
1.1 Operating modes of the gas computer.....	3
1.1.1 Gas computer for ideal gas.....	3
1.1.2 Measurement and calculation results.....	3
1.1.3 Setting the display in operation.....	4
1.2 CONNECTING THE MEASURED-VALUE TRANSDUCER.....	5
1.3 RESETTING THE COUNTER.....	5
2 PROGRAMMING THE μFLOW GK2	6
2.1 THE ACCESS LEVELS IN THE μ FLOW GK2.....	6
2.2 MENU AND KEY FUNCTIONS.....	6
2.3 PARAMETERIZATION OF THE INPUTS.....	8
2.3.1 Internal circuit diagram of the μ FLOW GK2 - input side.....	8
2.3.2 Flow inputs.....	9
2.3.2.1 Parameterization of differential pressure measurements.....	9
2.3.2.2 Further important parameters for parameterization of the flow inputs.....	9
2.3.3 Temperature inputs.....	10
2.3.3.1 Determining the input signal of the temperature measurement.....	10
2.3.3.2 Parameterization of the temperature measurement when using a measuring transducer.....	10
2.3.4 Parameterization of the pressure input.....	10
2.4 DEALING WITH THE OUTPUTS.....	11
2.4.1 The analog outputs.....	11
2.4.1.1 Assigning a measuring variable or operand to an output.....	11
2.4.1.2 Setting the characteristics and the full-scale values.....	11
2.4.2 The relay outputs.....	11
2.4.2.1 Assigning a measuring variable or operand to a contact.....	11
2.4.2.2 Selecting characteristics and setting the switching value.....	12
2.4.3 The counting pulse.....	12
2.4.3.1 Assigning a flow quantity to the counting pulse.....	12
2.4.3.2 Setting the pulse duration and pulse value.....	12
2.4.4 Using the RS232 interface.....	13
2.4.4.1 Connection and control of the μ FLOW GK2 with an industrial PC.....	13
2.4.4.2 Parameters.....	13
2.4.4.3 Example application of the generated file with Microsoft-Windows.....	15
2.5 MISCELLANEOUS.....	16
2.5.2 Querying the software version number and unit serial.....	
2.5.1 Programming the measuring point number.....	16
3 TECHNICAL SPECIFICATIONS	18
3.1 PERFORMANCE DATA.....	18
3.2 μ FLOW WIRING.....	19
3.2.1 115/230 VAC-Version.....	19
3.2.2 24 VDC-Version.....	19
3.3 MENU TREE OF THE μ FLOW GK2.....	20
4 TROUBLE-SHOOTING	21

1 APPLICATION AND OPERATION OF THE μ FLOW GK2

1.1 The μ FLOW as gas compensation computer

1.1.1 Operating modes of the gas computer

1.1.1.1 Gas computer for ideal gas

The μ FLOW GK2 in this setting is a compact computer for determining **two** standardized volumetric flows in **two** pipe systems, **independent** from each other.

In most industrial measuring procedures, gas density is required to standardized a volumetric flow. This density is not constant however, but changes with pressure and temperature, with the precondition that the gas composition remains the same. Referred to a standard density ρ_N at a temperature of $T_N = 273.15 \text{ °K}$ ($= 0 \text{ °C}$) and a pressure $p_N = 101.325 \text{ kPa}$, the actual density ρ in measuring mode with the conditions operating temperature T and operating

pressure p results in $r = \frac{T_N}{T} * \frac{p}{p_N} * r_N$

This is a basic relationship which helps to determine the so-called standard volumetric \dot{V}_N in the μ FLOW.

Using the general law for ideal gases, the basic formula for standard volumetric flow results (\dot{V}_{akt} is the current, non-standardized volumetric flow):

$$\dot{V}_N = \frac{p}{p_N} * \frac{T_N}{T} * \dot{V}_{akt}$$

1.1.2 Measurement and calculation results

The input variables are

- the velocity or the differential pressure supplied by a differential pressure transducer in the form of an injected currents 4-20 mA
- a temperature-proportional current (4-20 mA) or the ohmic resistance of a Pt100 resistance thermometer for determining the medium temperature T
- a current (4-20 mA) proportional to the absolute pressure p_{abs}

The standardized volumetric flow is determined from these variables and this serves as the basis for further processing steps.

1.1.3 Setting the display in operation

The table below shows the sequence of the various displays in the operating mode "Gaseous media measurement".

By pressing the "↓" key, it is possible to switch between the displays in descending order of the table. By pressing "↑" key, it is possible to switch in the opposite direction. By pressing the SELECT key, the measuring point number (TAG number) is displayed which can be freely programmed by the user (see Section "Programming the measuring point number").

Physical variable	Display in the μ FLOW display
Standard volumetric flow	Vn1= 50631Nm ³ /h
Medium temperature, absol. pressure in system 1	t1=116 °C p1=98.8kPa
Standard volumetric flow	Vn2= 10520Nm ³ /h
Medium temperature, absol. pressure in system 2	t2=116 °C p2=98.8kPa
Standart volumetric flow in system 1 and 2	Vn1= 50631Nm ³ /h Vn2= 10520Nm ³ /h
Actual volumetric flow in system 1	V1= 5621Nm ³ /h
Standard volumetric flow in system 1	Vn1= 50631Nm ³ /h
Actual volumetric flow in system 2	V2= 5621Nm ³ /h
Standard volumetric flow in system 2	Vn2= 10520Nm ³ /h
Summator standard volumetric flow system 1 and 2	$\sum V1= 109275Nm^3$ $\sum V2= 99176 Nm^3$
summator standard volumetric $\sum V1+\sum V2$	$\sum V= 208451Nm^3$ A1=NORM A2=MAX
state of the alarm contacts/relay	
Branching to subdisplay for peak value query	SELECT drücken> MIN/MAX-Abfrage

1.2 Connecting the measured-value transducer

Three illustrations are located on the rear of the μ FLOW for connection of the respective measured-value transducer. A distinction is made between three types of signal sources:

<p>2-wire transducers (power supply 24 V DC/120 mA for maximum six measuring transducers)</p> <p>⊕- terminal of the measuring transducer to μFLOW 24 V output</p> <p>GND or ⊖- terminal to respective μFLOW IN input</p>	
<p>Active signal sources with an output signal 4-20 mA</p> <p>⊕- of the measuring transducer to the respective μFLOW IN input</p> <p>GND or ⊖-terminal to μFLOW GND terminal</p>	
<p>Pt100 resistance thermometer in accordance with DIN 43760</p> <p>The three supply lines to the measuring shunt must have the same ohmic resistance.</p>	

1.3 Resetting the counter

The summator and heat quantity counter may be reset by simultaneously pressing both **RESET** keys when the counter is actually being displayed. This action is prevented if the unit is locked. Incorrect or unintentional resetting is largely ruled out.

The counts are backed up in the event of power failure and are then protected by a special hardware function against unintentional overwriting.

2 Programming the μ FLOW GK2

2.1 The access levels in the μ FLOW GK2

A distinction must be made between the operating level and the parameterization level when using the μ FLOW GK2

When the unit is started and initialization complete, the μ FLOW moves directly into the measuring and control mode. It is possible to branch into the parameterization level from here by simultaneously pressing the two "PROG" keys. In this way, only those parameters permitted within the framework of the set hierarchy level are released for modification.

If the unit is "BLOCKED!", an ID code (identification code) must be input before entry in the parameterization level. Otherwise, the ID code itself may be changed in the parameterization level.

The hierarchy levels are as follows:

Level	ID Code	Permitted
blocked!	0000	nothing
Operation	1508	Resetting the counter, query information in the menu "INFO" but change nothing
Engineer	2552	Standard level for input of process parameters; this level is sufficient for the requirements of the process engineer and the qualified operating personnel.

The access level may be lowered in the menu option "ACCESS\LEVEL". The access levels located in the hierarchy below the currently valid level are always located here for selection. Extended access authorization is only possible by inputting the corresponding code in the menu option "ACCESS/ID-NR."

2.2 Menu and key functions

The μ FLOW GK2 menu system is organized into various levels. The selection options of a level always appear in the display.

The operating steps are the same within this programming level. Operation is always performed with one or several of the five operating keys. Their functions depend on the respective operating situation.

Various instruments used in the situation given below are available for programming:

Menus consist of several selection options from which one may be selected in each case. Menu options are controlled with the horizontal arrow keys "←", "→" and selected with the SELECT key. The cursor indicates which menu option is currently active. The hierarchy structure of the menus is explained in section "Menu tree of the μ FLOW". Menu options may branch into submenus, "Option menus", input lines for character strings, whole numbers and reel numbers. To move from one menu to the next highest menu, the obligatory menu option "END" must be selected and confirmed with the SELECT key. It is also possible to press the two RESET keys. In this case, it is not necessary to move to the selection option "END" beforehand. It is also possible to move through all menus at high speed without having to work

through the vertical arrow keys, the menu option "END" and the SELECT key. The highest menu level has a particular feature: Confirmation with the RESET keys leads at this point to quitting the parameterization level without saving the parameters in EEPROM. In this case, the changes are retained only until the next operating power interruption. This special feature is suitable for testing certain settings without overwriting the old programming values.

Option menus are merely a special form of a menu. The simplest form of an optional menu consists in the selection of the options "YES__NO". Option menus operate the same way as "proper" menus. The currently selected option appears in the first line of the display. The currently valid parameterization is therefore clear. Selection takes place by pressing SELECT, cancel without selection by pressing both RESET keys.

Input of character or letter strings: The current contents of the character string is predetermined by selecting an input function. A character to be changed is activated by one of the horizontal keys and may be changed with the vertical keys "↑", "↓". Numbers may be changed only within the preset limits.

In the case of real or integer numbers, a message appears in line 1 giving the range limits of number input, the ACTUAL value appears in line 2 and then the unit of the variable to be input.

In the case of alphanumeric character strings, the first display line contains a message referring to the character string currently being processed.

The SELECT key serves in this function to accept the displayed string of digits. The RESET keys have the same meaning; in this case, input will not be deleted if these keys are pressed.

2.3 Parameterization of the inputs

2.3.1 Internal circuit diagram of the μ FLOW GK2- input side

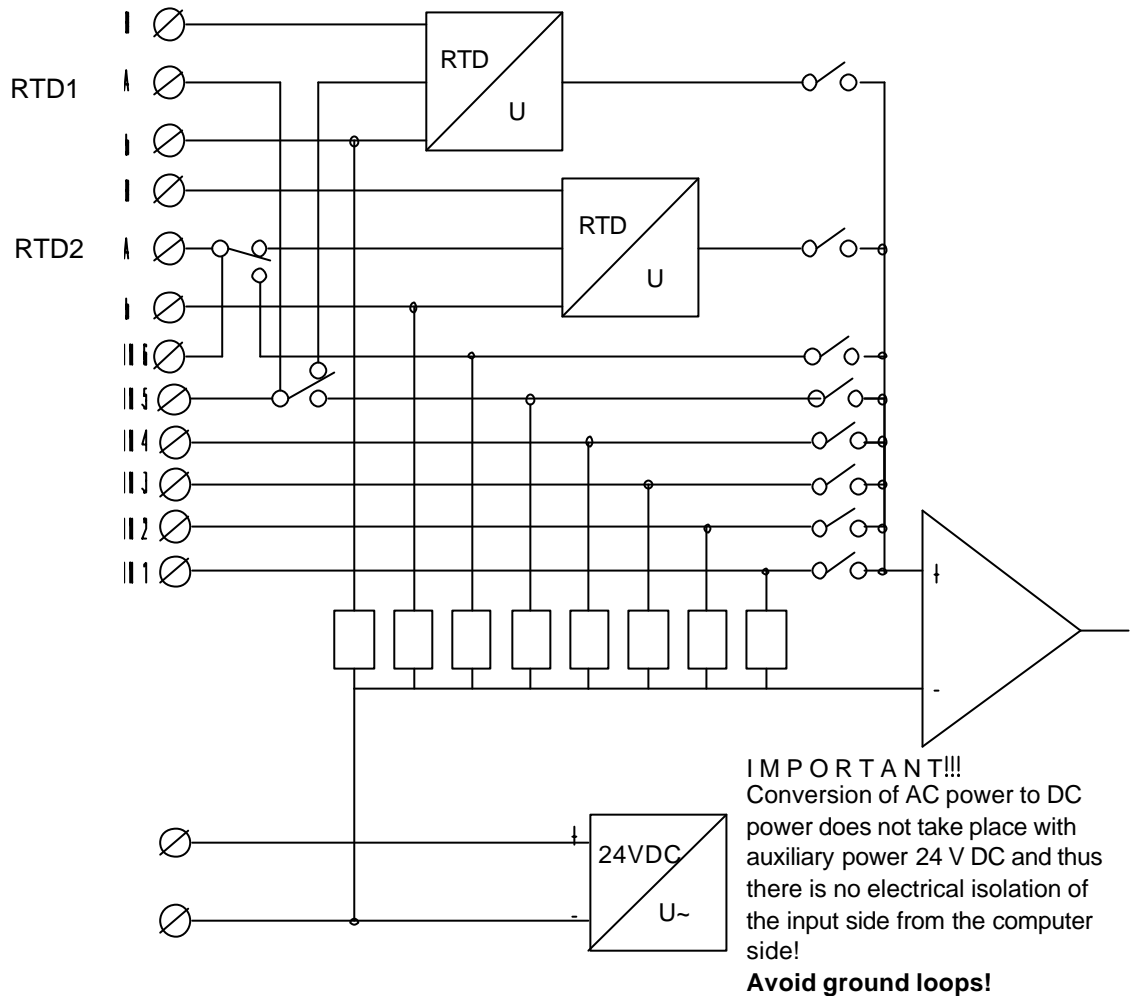

Inputs	Terminal No.	Term
IN1	33	Flow input 1 4-20mA
IN2	32	Flow input 2 (measure range extension) 4-20mA
IN3	31	not used
IN4	30	pressure input 4-20mA
IN5	25	temperatur input 1 4-20mA (depending from position of DIP-Switches)
IN6	28	temperature input 2 4-20mA (depending from position of DIP-Switches)
RTD1 B-A-b	24,25,26	temperature input Pt100 resistance Thermometer (depending from position of DIP-Switches)
RTD2 B-A-b	27,28,29	temperature input Pt100 resistance Thermometer (depending from position of DIP-Switches)

FREQ+	18	Frequency input
-------	----	-----------------

2.3.2 Flow inputs

2.3.2.1 Parameterization of differential pressure measurements

Parameters which can be set are:

Lower measuring range limit value of the differential pressure measuring transducer Δp_{min} (menu option "\PARAMS\FLOW1\DIFF.P\DP.MIN"): this value is specified in *mbar*.

Upper measuring range limit value of the differential pressure measuring transducer Δp_{max} (menu option "\PARAMS\FLOW1\DIFF.P\DP.MAX"): This value is also specified in *mbar*.

The transfer coefficient *k* of the differential pressure transducer (menu option "\PARAMS\FLOW1\DIFF.P\K-VALUE"): When using pitostatic tube sensors, the used tube is always accompanied by a calculation sheet from which the *k*-factor is obtained. In the case of unknown *k*-factors, the *k*-factor can be calculated simply; the following applies for standard volumetric flows:

$$k = \sqrt{\frac{r_N * T_A}{\Delta p * p_A} * \frac{15,23 * V_N}{D_i^2}}$$

Units used:

$\left[\frac{\bullet}{m} \right] = \frac{kg}{h}$	mass flow	$[r_N] = \frac{kg}{Nm^3}$	Standard density at T= 273.13 K and p = 101.325 kPa
$[V_N] = \frac{Nm^3}{h}$	Standard volumetric flow	$[r] = \frac{kg}{m^3}$	Density of the medium under operating conditions
$[D_i] = mm$	Inside diameter of the pipeline	$[p_A] = kPa$	Design pressure (absolute) of the medium
$[\Delta p] = mbar$	Differential pressure at full flow	$[T_A] = K$	Design temperature

The transfer characteristics of the differential pressure transducer (menu option "\PARAMS\FLOW1\DIFF.P\DP<->\sqrt{DP}"): A square-root characteristic (menu option "\PARAMS\FLOW1\DIFF.P\DP<->\sqrt{DP}\INOC\sqrt{DP}") or a differential-pressure-linear characteristic (menu option "\PARAMS\FLOW1\DIFF.P\DP<->\sqrt{DP}\INOC\sqrt{DP}") may be selected.

2.3.2.2 Further important parameters for parameterization of the flow inputs

The pipeline inside diameter (menu option "\PARAMS\FLOW1\ID_ROHR"): This is specified in *mm*. Correct specification of this value is of decisive importance for measurement accuracy particularly in the case of differential pressure measurement.

The creep quantity (menu option "\PARAMS\FLOW1\SCHLEICH"): This is specified in % of the maximum possible volumetric flow. ¹

¹ At this point, a case should be made for generous measurement of the low flow cutoff. It has been shown that differential pressure measurement errors in the "lower" range are increasing due to the

2.3.3 Temperature inputs

2.3.3.1 Determining the input signal of the temperature measurement

Temperature measurements in μ FLOW GK2 may be made either via the direct connection of a Pt100 resistance thermometer or via connection of a temperature measuring transducer with an unit signal output 4-20 mA. To ensure correct setting, it is first of all necessary to correctly set the DIP switches located inside the unit behind the connection terminals for the temperature measurements. The following table shows the configuration:

	Pt100	Temperature-transducer
Switch 1	OFF	ON
Switch 2	ON	OFF

The required operating mode must also be specified in the menu "\PARAMS\TEMP1\AUSWAHL". Possible entries here are: "PT100" for resistance thermometer and "TEMP-XMT" for temperature measuring transducer with current output signal."

2.3.3.2 Parameterization of the temperature measurement when using a measuring transducer

No further parameterization need be carried out on a Pt100 thermometer; its standard application range lies between -200 and +550 °C. In the case of temperature measuring transducers, the μ FLOW GK2 must be set to the corresponding measuring range limits of the temperature signal transducer.

Lower measuring range limit T_{\min} (menu option "\PARAMS\TEMP1(2)\T.MIN"): Setting in °C.
Upper measuring range limit T_{\max} (menu option "\PARAMS\TEMP1(2)\T.MAX"): Setting also in °C. (Setting range -200 ...+1200 °C)

2.3.4 Parameterization of the pressure input

Lower measuring range limit² ρ_{\min} (menu option "\PARAMS\TEMP1(2)\P.MIN"): Setting in *kPa abs.*

Upper measuring range limit ρ_{\max} (menu option "\PARAMS\TEMP1(2)\P.MAX"). Setting also in *kPa abs.* (Setting range 0 ... 11000 kPa)

principles used. Other procedures show the same behavior, even if due to other reasons. Zero point errors also occur due to temperature influences or pipeline vibrations (vortex). It may therefore arise that several hundred kg of steam are summated over weekends in a pipeline with closed valve. This can be avoided: A low flow cut-off of at least 5 % is therefore suggested.

² The zero point is frequently set at absolute vacuum (0 bar abs.) when using absolute pressure measuring transducers. However, neither steam state nor gas state is defined here. This may lead to undefined calculation results with corresponding consequences for the plausibility of the calculation results. The volume calculated will be infinitely large. Avoid miscalculation by suitable parameterization of the pressure input (for example $\rho_{\min} = 1$ kPa).

2.4 Dealing with the outputs

2.4.1 The analog outputs

The analog outputs of the μ FLOW GK2 are electrically isolated from the rest of the system and manage a load of max. 500 Ohm. Their resolution is 10000 steps (2 μ A/step).

2.4.1.1 Assigning a measuring variable or operand to an output

Any number of process variables or state variables may be assigned to up to two analog outputs of the μ FLOW GK2. The following table shows the possibilities depending on the set operating mode:

Set process	Menu option	Significance
Gaseous media	$\dot{V}.norm$	Standard volumetric flow
	$\dot{V}.akt$	Actual volumetric flow (non-standardized)
	t	Medium temperature
	p	Absolute pressure in the medium

2.4.1.2 Setting the characteristics and the full-scale values

Output characteristics (menu option "\Params\Ausgang\Analog1\Charakt"): It is possible to set the outputs to 0 - 20 mA (menu option "\PARAMS\OUTPUT\ANALOG1\CHARAKT\0-20 MA") or 4-20 mA ("life zero") (menu option "\PARAMS\OUTPUT\ANALOG1\CHARAKT\4-20 MA") independently of each other.

Lower full-scale value (menu option "\PARAMS\OUTPUT\ANALOG1\LO-VAL"): The setting is made referred to the assigned physical variable and is therefore without dimension; setting limits 0...2000000.

Upper full-scale value (menu option "\PARAMS\OUTPUT\ANALOG1\HI-VAL"): The setting is made without dimension as for the lower full-scale value; setting limits 0...2000000.

2.4.2 The relay outputs

The output relays of the μ FLOW GK2 are floating contacts with a contact load rating of 8A at a nominal voltage of 250 V AC (service life under full load: 10⁵ cycles).

2.4.2.1 Assigning a measuring variable or operand to a contact

Any number of process or state variables may be assigned to the two contacts of the μ FLOW GK2. The following table shows the possibilities depending on the set operating mode:

Set process	Menu option	Significance
Gaseous media	$\dot{V}.norm$	Standard volumetric flow
	$\dot{V}.akt$	Actual volumetric flow (non-standardized)
	t	Medium temperature

p	Absolute pressure in the medium
-----	---------------------------------

2.4.2.2 Selecting characteristics and setting the switching value

Switching characteristics of the relay outputs: (menu option "PARAMS\OUTPUT\RELAIS1\CHARAKT"): The following are possible: Minimum alarm (option "MIN") and maximum alarm (option "MAX")

Switching value: (Menu option "\PARAMS\OUTPUT\RELAIS1\VALUE"): The setting is made without dimension referred to the assigned physical variable; setting limits 0..2000000.

The FAIL contact cannot be configured because it is not under involuntary control of the μ FLOW operating program.

2.4.3 The counting pulse

The signal from the back "CNT" terminal is the pulse of an open collector which is always given when the assigned added quantity or energy is increased by 1. The pulses therefore occur irregularly and do not correspond to the current flow rate.

The "CNT" output is **not** connected to any voltage. Therefore, commercially-available counters may be connected which mostly have supply voltages for the pulses of relay contacts or open collectors available at their inputs. Should this not be the case, connect in accordance with the following connection diagram:

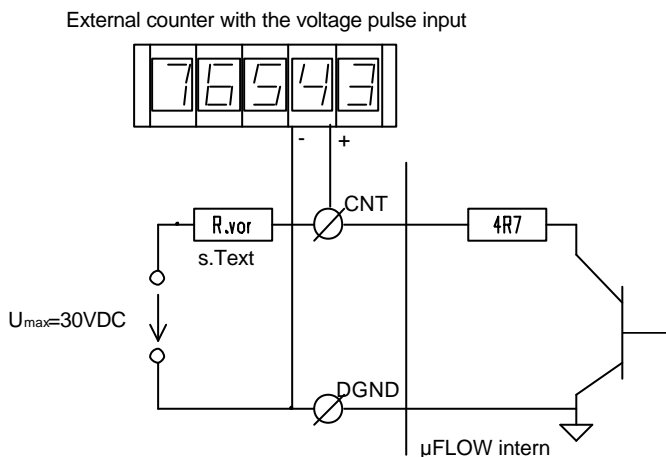

The pulse pulls the voltage to DGND. The transistor is a generously dimensioned Darlington model which functions here as a current sink. This current is limited by the internal series resistor so that only an output of approx. 1 W can be switched. It is therefore necessary to connect an appropriately dimensioned external series resistor so that the permissible switching output is not exceeded. In general, a series resistor in the range of 1 to 10 K should be used thus guaranteeing safe operation with

voltages of more than 24 V DC.

2.4.3.1 Assigning a flow quantity to the counting pulse

The counting pulse is permanently assigned to the standardized volumetric flow " $\Sigma \dot{V}.norm$ ". The output is integrated over time in addition to the summation of the volumetric flow .

2.4.3.2 Setting the pulse duration and pulse value

Pulse duration (menu option "PARAMS\OUTPUTS\PULSE\DURAT."): The setting possibilities are 10 or 50 milliseconds; this should be set depending on the specifications of the connected counter.

Pulse value (menu option "PARAMS\OUTPUTS\PULSE\SCALE): The setting possibilities are the transformation ratios 1:1, 1:10, 1:100 and 1:1000. Example: With a transformation ratio of 1:10, one pulse corresponds to ten displayed volumetric or mass units.

2.4.4 Using the RS232 interface

The RS232 interface supports data logging operation i.e. the recording of measurement results with the PC. It is planned for the future to extend the software to allow configuration of the μ FLOW via the RS232 interface as well as the combination of several μ FLows in one system.

2.4.4.1 Connection and control of the μ FLOW GK2 with an industrial PC

The μ FLOW and PC are connected via a three-core cable with a maximum length of 10 m. The TxD terminal on the μ FLOW must be connected with the RxD line on the PC interface and conversely the RxD terminal on the μ FLOW with the TxD line on the PC.

The selection of a suitable interface for the PC depends on its concrete assignment with serial COM interfaces. If the option exists, the terminal software used should set the COM interface to operations *without log* or *with XON/XOFF log*. Should only a hardware log be planned, the corresponding handshake lines on the serial interfaces must be shorted.

2.4.4.2 Parameters

For reasons of clarity, the setting possibilities of the parameters are limited to the influencing variables which are really important for operation of the serial interface. The number of data bits and stop bits and the parity may therefore not be set. In accordance with the transfer parameters selected in most application cases, the μ FLOW transmits with

- 8 data bits
- 1 stop bit
- no parity
- with XON/XOFF log

The baud rate and the time between two transfers may be set.

2.4.4.2.1 Setting the baud rate

The transfer rate may be influenced by the baud rate. The baud rate determines transfer reliability in critical cases. Reducing the rate may provide a remedy in the event of data transfer with interference. (This procedure is selected for example for so-called "Overseas connections" in fax units.)

The baud rate is set in the menu "/PARAMS/OUTPUTS/RS232/BAUD" on the μ FLOW. 4800 and 9600 bauds are possible. Operation with 9600 baud should be attempted at first.

2.4.4.2.2 Setting the duration of the transmission cycle

The transmission cycle directly influences the occurring data flow. The data to be saved should be reduced to a reasonable quantity since data flows normally in slow processes. For this reason, the μ FLOW supports a minimum time period of 5 seconds. However, care still needs to be taken because approximately 30 characters per transfer gives rise in this case to 360 characters per minute, 21600 characters per hour and 518400 characters per day. This is not

a sensible amount for the majority of cases. In addition to the large amount of memory space required, evaluation of this data in particular is made significantly more difficult.

2.4.4.2.3 Log

The low absolute transfer rates should not give rise to conflicts in communication between the μ FLOW and the PC. A log is actually superfluous for this reason. However, the transmission activity of the μ FLOW may be interrupted by an XOFF signal transmitted by the PC and may then be continued with an XON signal. Should the interruption last longer than one transmission cycle, the data transmitted inbetween are ignored.

2.4.4.2.4 Data format

The μ FLOW transmits text character strings (ASCII) with information about the current flow, the status of the summator and the primary state data pressure and temperature.

The individual values are separated by blanks (ASCII code 32).

A typical line may look as follows:

```
2436 192873 23.4 101
```

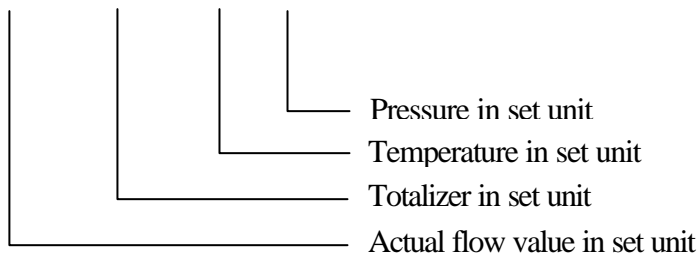

At the μ FLOW GK2 data is transferred in the following order

- standard volumetric flow 1
- actual volumetric flow 1
- total standard volumetric flow 1
- standard volumetric flow 1
- actual volumetric flow 2
- total standard volumetric flow 1
- addition of the total standard volumetric flow 1 and 2
- temperatur 1
- temperatur 2
- absolute pressure 1
- absolute pressure 2

2.4.4.3 Example application of the generated file with Microsoft-Windows

The following is intended to provide a description of example measuring data acquisition and processing with a standard PC using Microsoft-Windows. Other systems offer generally comparable performances so that the following instructions are transferrable in principle.

2.4.4.3.1 Data input with TERMINAL

MS-Windows 3.1 offers a simple terminal program in its system resources which is, however, well suited for data acquisition from μ FLOW. In the menu option "Setting/Data transfer", the following settings are made in accordance with the above versions: Baud rate 9600; data bits: 8; parity: none; log: none; stop bits: 1; connection: in accordance with the interface assignment; plausibility check: OFF; carrier signal detection: OFF.

Data should already appear on the screen after a waiting period between two transmission cycles have expired if a connection to the μ FLOW exists. When performing tests, it is practical to set this cycle time on the μ FLOW to 5 seconds in order to obtain a prompt reaction.

After performing connections and correctly setting all parameters, data acquisition can now take place without any problems. Memory setting on hard disk is performed in the menu option "Transfer/Text file received". Here you must enter the directory and name of the measurement

file to be created corresponding to usual practice when using Windows 3.1. Acquisition then takes place immediately. Please observe any possible conflicts with other application programs. It is recommended not to run any other programs during measuring data acquisition. Windows is not a real-time multitasking system developed for such tasks.

Data acquisition is completed in the window for data reception by clicking on the "Abort" button. The file is now closed and may be worked on.

2.4.4.3.2 Processing data with WINWORD 6.0

The file created with the terminal is in table format. The individual fields are separated by a blank. The entire file may be entered with a text processing program such as WINWORD 6.0. The entire file can be transferred to a WINWORD table by selecting the Winword menu option "Table/Convert text to table" after marking the entire text with "Ctrl" and "Num 5" ("5" on the numerical PC keyboard).

Winword 6.0 offers the possibility of working with this table or saving it and working in another Windows program. The data stock can be transferred, for example, by copying the file into the interim memory and then inserting it into a user program such as EXCEL, PARADOX or similar.

2.4.4.3.3 Processing data with EXCEL 5.0

EXCEL 5.0 offers the possibility of entering texts structured in tables. Use here the command "File/Open" and select the file type "Text files (*.prn;*.txt;*.csv)". After clicking the "OK" button, EXCEL opens the text assistant. The original file can then be specified in several steps. First select here the "original file type" "*separated*": In this way, EXCEL is informed that the numbers contained in the text lines may have a varying number of digits.

Now press the "CONTINUE>" button. The second step of the text assistant permits EXCEL to specify a separator. The correct setting is the blank " ". The preview permits you to check separation by EXCEL 5.0. You have probably input the German decimal comma as the decimal character. EXCEL is then unable to interpret the corresponding μ FLOW data as numbers since this uses the standard international decimal point. In this case, you may temporarily change the decimal character to the decimal point in windows system control under the feature "Country settings" so that the number chains supplied by μ FLOW can be correctly interpreted by EXCEL.

By clicking on the "CONTINUE>" button, the 3rd step of the EXCEL text assistant is performed. Here you may delete individual columns so that you are then able to selectively further process only the μ FLOW data.

The file is formatted in EXCEL format by clicking "END" and evaluation may begin. Do not forget to save the processed file in EXCEL format if possible.

2.5 Miscellaneous

2.5.1 Programming the measuring point number

The μ FLOW GK2 offers the possibility of determining a measuring point number (TAG number) which may be made visible by the operating staff at any time - practical particularly when using separate units at the same time. This is programmed in the menu option "\PARAMS\TAG-NR."

The TAG number may be queried at the operating level by pressing the SELECT key. The display is cancelled when the SELECT key is pressed a second time.

2.5.2 Reading back the software version number and unit serial number

It may be practical to know important unit data in the event of queries from the manufacturer or the sales company. These may be read in the menu "\ INFO ":

- Software version number (menu option "\INFO \VERSION ")
- Unit serial number (menu option "\INFO\SER.NR.")

3 Technical specifications

3.1 Performance data

Enclosure:	Plastic enclosure, front dimensions 144 x 72 mm ² (DIN)
Mounting depth:	approx. 170 mm
Switching panel projection:	138 x 68 mm
Power supply	220 V AC/50 Hz ($\pm 10\%$) 24 V DC/300 mA (optional)
Maximum mains interference:	150 V/20 ms, followed by automatic RESET by integrated monitoring module with backup of the count.
Functional test:	Watchdog, FAIL function with drop-out contact in the event of a fault
Maximum load rating of the contacts:	250 V AC/5 A
Available auxiliary power:	24 V DC/160 mA for transmitter supply: (with auxiliary power 110/220 V AC only) No transmitter supply is possible with auxiliary power 24 V DC
Analog inputs	Internal resistance 24 Ohm per current input > 10 MOhm for Pt100
Analog/digital converter	16 bit resolution with integrated 50 Hz suppression; complete electrical isolation from the computer and all outputs (except in the case of transmitter supply)
Counting pulse load rating	max. 1 W, max. 30 V
Maximum load of the analog outputs	500 Ohm
Resolution of the outputs	14 bits, completely electrically isolated from the computer and all inputs and outputs

3.2 μFLOW wiring

3.2.1 115/230 VAC-Version

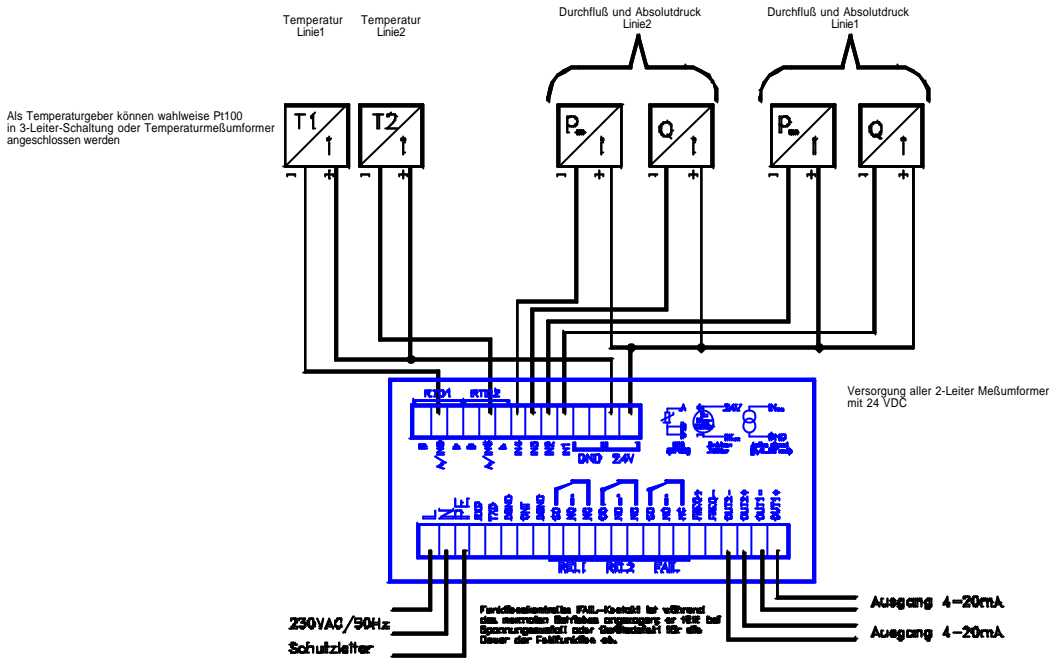

3.2.2 24 VDC-Version

Units with 24 V DC supply voltage are unable to supply measuring transducers. The auxiliary power required for this must be taken from the μFLOW supply terminals if necessary.

Please also observe the internal circuit diagram of the μFLOW. On the 24 V version, electrical isolation does not exist between the digital and analog side. Only the analog outputs are electrically isolated further. This applies in particular to the connection of active current sources at the point of the normal two-wire transmitter.

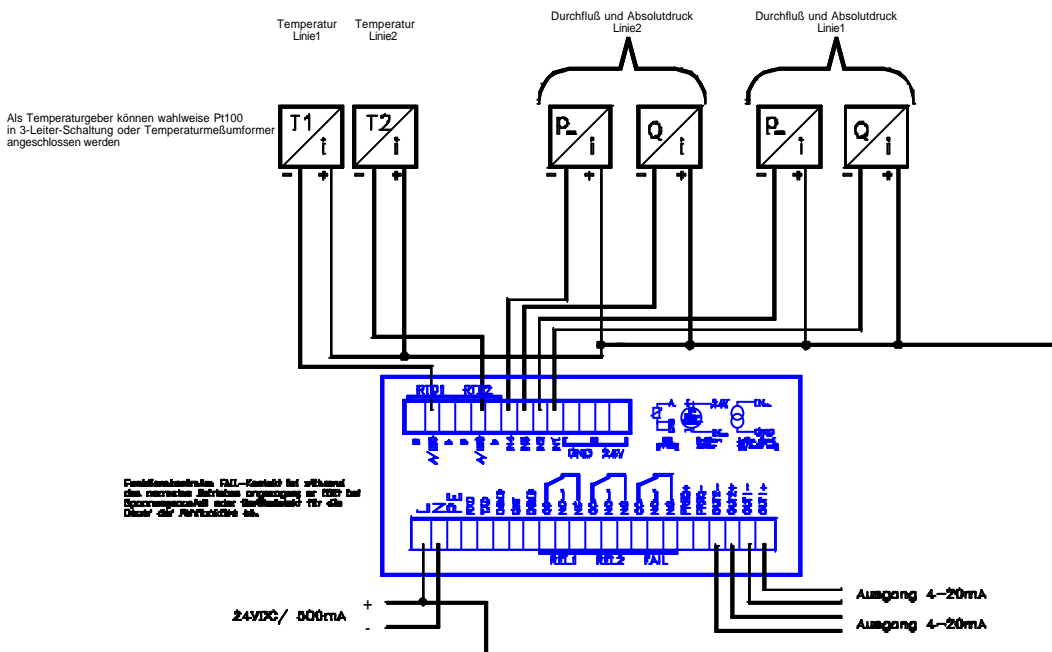

3.3 Menu tree of the μ FLOW³

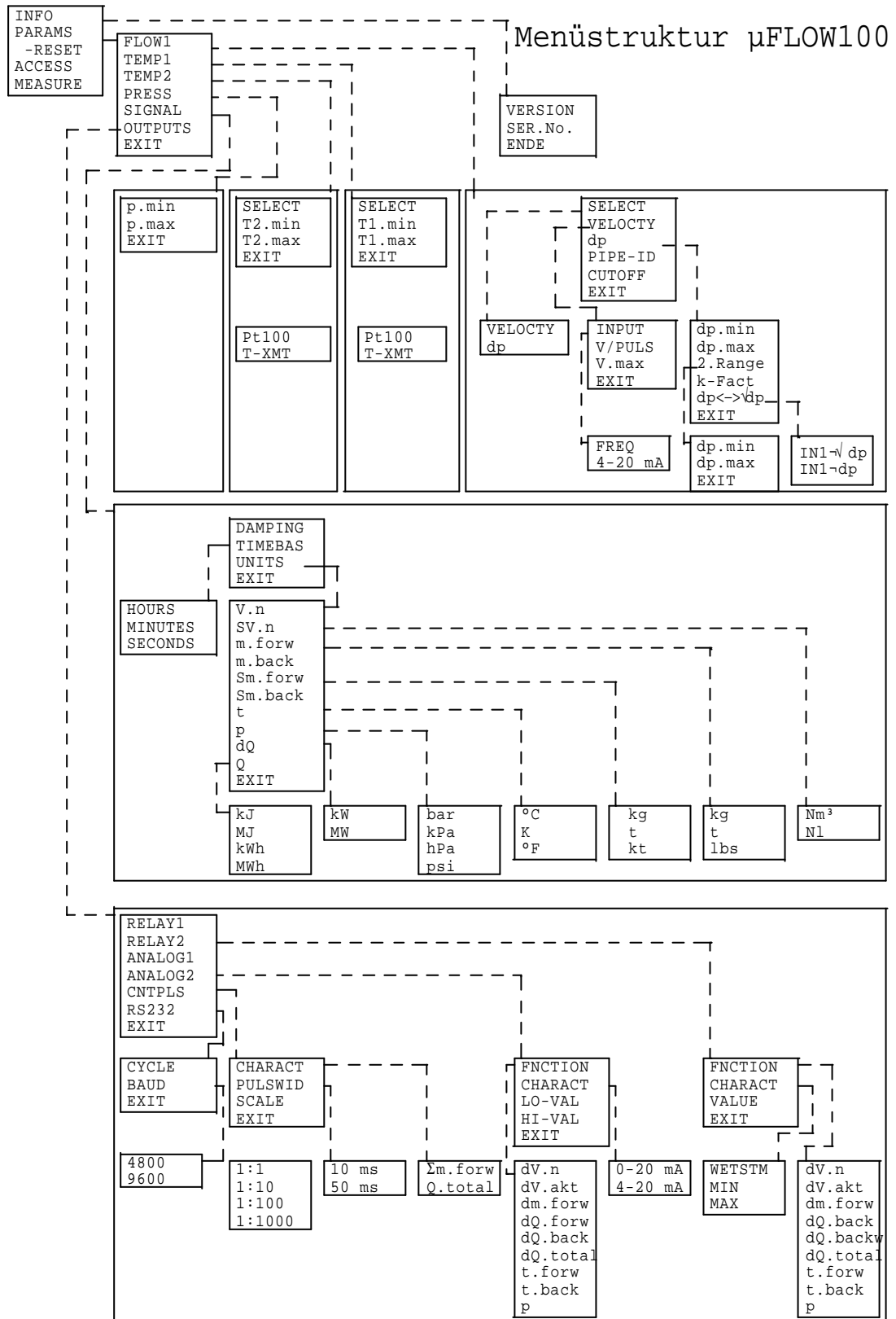

³Please note: Not all menu options are available on all computers. This is due to the configuration of the computer. Computers without analog outputs naturally do not require this menu option. Other menu options may be masked out by user parameterization. Example: When using a Pt100 resistance thermometer, specification of the measuring range limits of a temperature measuring transducer is naturally superfluous.

4 Troubleshooting

The error sources shown in the following table occurring during operation and the remedial possibilities are constantly being updated in accordance with experienced gained from practice.

Error	Causes	Remedy
Temperature display incorrect	Incorrect sensor type selected	Specify correct transducer type in the menu "PARAMS/TEMP1/AUSWAHL"
	Internal DIP switches incorrectly set	Remove enclosure rear panel and correct setting of the DIP switches
Thermal flow display shows "NaN" or "N"	Calculation result makes no sense	Return line measurement incorrectly parameterized; if measurement is not performed in the return line, the respective temperature input Temp2 must be set to "Measuring transducer" and the limits T_{\min} and T_{\max} to "0". The heat transported in the return line will then also be equal to "0".