μFLOW 20

**Compact computer
for gaseous media and
heat**

Instruction Manual

July 2001

valid from software version 20-1.9917

UF2-006-01.doc

content

| | |
|--|-----------|
| Explanations of symbols | 3 |
| General Hints | 3 |
| Qualified Personnel | 3 |
| Technical data | 4 |
| Dimensions | 4 |
| Mechanical mounting | 4 |
| Cleaning | 4 |
| General hints for Electrical connection | 5 |
| Exchange of the fuses | 5 |
| Application and Operation of the μFlow | 5 |
| Basic functions of the μ FLOW 20 | 5 |
| Measurement and calculation results | 5 |
| The displays | 5 |
| Connection examples for inputs | 6 |
| The terminals in detail | 7 |
| Programming the μFLOW | 8 |
| The access levels in the μ FLOW | 8 |
| Menu and key functions | 8 |
| Resetting the counter | 9 |
| Parameterization of the inputs | 9 |
| Determination of the operating mode of the flow measurement | 9 |
| Parameterization and setting of frequency signals | 9 |
| Parameterization of current signals (4-20 mA) | 9 |
| Further important parameters for the parameterization of the flow inputs | 10 |
| Dealing with the outputs | 10 |
| The analog outputs | 10 |
| Setting the characteristics and the full-scale values | 10 |
| The relay outputs | 10 |
| The counting pulse | 10 |
| Setting the pulse duration | 11 |
| RS232 Interface | 11 |
| Using the interface | 11 |
| Connection and control of the μ FLOW with an industrial PC | 11 |
| Parameters | 11 |
| Setting the baud rate | 11 |
| Setting the duration of the transmission cycle | 11 |
| Log | 11 |
| Data format | 11 |
| Example application of the generated file with Microsoft-Windows | 12 |
| Data input with TERMINAL | 12 |
| Processing data with WINWORD 6.0 | 12 |
| Processing data with EXCEL 5.0 | 12 |
| Miscellaneous | 13 |
| Programming the measuring point number | 13 |
| Querying the software version number and unit serial number | 13 |
| Trouble shooting | 14 |
| Description of the failure | 14 |
| Possible reason | 14 |

Explanations of symbols



Warning of a danger place (caution: consider documentation)
ISO 3864, No. B.3.1



Warning of dangerous electrical voltage
ISO 3864, No. B.3.6

General Hints

For reasons of clarity this manual does not contain detailed information about all types of products and cannot take into account every conceivable case of installation, operation or maintenance.

If you require further information or should problems occur which are not sufficiently explained in the manual, you can consult us directly to obtain the necessary information.



CAUTION

This equipment is a Limit Class A once. It can cause radio disturbance in residential. On this case customer has to take care appropriate measure.

This equipment should only be installed and operated after qualified personnel have ensured that suitable power supply (see name plate) will be used and that during normal operation or in case of a defect in the system or in components no hazardous situation can occur. Therefore serious injuries and/or considerable material damage cannot be ruled out in the event of improper handling of the device.

The perfect and safe operation of this equipment is conditional upon proper transport, proper storage, installation and assembly as well as on careful operation and commissioning.

May we also draw your attention to the fact that the contents of the manual are not part of a previous or existing agreement, approval or legal relationship or an amendment thereof. All obligations of the vendor result from the contract of purchase which also contains the full and solely valid warranty agreement. These contractual warranty conditions are neither extended nor restricted by the contents of the manual.

Qualified Personnel

are persons familiar with the installation, assembly, commissioning and operation of the product and who have the appropriate qualifications for their activities such as:



- Training or instruction or authorization to operate and maintain devices/systems according to the standard of safety technology for electrical installations.
- Training or instruction in the proper care and use of protective equipment in accordance with appropriate safety practices.
- Rendering first aid.



attention

During startup no button on the front panel must be pressed

Technical data

| | |
|----------------------------|--|
| indication: | LC-Display, 2 lines with 16 signs |
| nominal voltage: | 230 VAC ($\pm 10\%$) 115 VAC (optional) 24 VDC (optional) |
| frequency range: | 50 Hz $\pm 10\%$ |
| nominal current: | 65 mA @230/115V 50Hz 500 mA @24 VDC |
| nominal power | 15 VA @230/115V 50Hz 12 VA @24 VDC |
| maximum main interference: | 150 V/20 ms, followed by automatic RESET by integrated monitoring module with backup of the count |
| EMV tests: | according to EN 55011/ 55011-A1; EN 61326-1/ 61326-A1 and EN 50082-1/2 |
| Functional test: | Watchdog, FAIL function with drop-out contact in the event of fault |
| Available auxiliary power: | 24 VDC/160 mA for transmitter supply (with auxiliary power 115/230 VAC only) No transmitter supply is possible with auxiliary power 24 V DC |
| analog inputs: | 4-20 mA Internal resistance 24 Ohm per current input |
| Analog/Digital converter | 14 bit resolution with integrated 50Hz-suppression; complete electrical isolation from the computer and all outputs(except in the case of transmitter supply)) |
| Frequency input: | 0,1 up to 10kHz |
| Analog outputs: | 1x 4-20 mA, optional 2x 4-20 mA max. load: 500 Ohm |
| count pulse: | max. 1W, max 30 V |
| resolution of the outputs: | 14 bits, completely electrically isolated from the computer and all inputs |
| relay outputs: | 2x free configurable, 1x Fail-relay max. load of the contacts: 250VAC/8A |



***Caution:** Before installation and operation customer has to check the nominal voltage. Only the declaration on the type plate is guilty!

Dimensions

| | |
|-------------------|--|
| enclosure: | glass-fibre-reinforced Noryl, front panel 144x72 mm ² (DIN) |
| material: | Noryl SE1 GFN2 |
| protection class: | IP 20 (enclosure); IP64 (display unit) |
| depth: | ca. 170 mm |
| panel cut-out: | 5.45" x 2.7" (138 x 68 mm ²) |

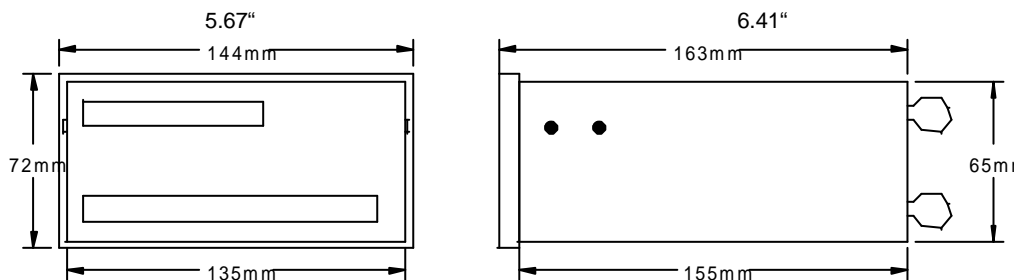

Mechanical mounting

The standard μ flow is a panel mounting unit. After preparing the panel cut-out, customer has to mount the μ Flow while using the delivered mounting brackets. Please pay attention to use the delivered seal between panel and μ Flow-housing.

Cleaning

The μ Flow has to be cleaned only with a dry daster.

General hints for Electrical connection



Signal leads must be shielded, one end of the shield has to be connected to mass. Signal and main leads have to be laid seperately.

For electrical installation following determinations are to be observed:

- power supply wiring has to be designed for nominal current
- power supply has to be installed, so that the power supply of μ Flow can be switched off
- switch off power supply before opening the μ Flow

Exchange of the fuses

The main fuse is located on the main circuit board (see picture on the right). The fuse for the 24 V auxiliary power is located on the CPU circuit bord (see picture 11. The fuses are reachable after dismantling of the back panel. The type of fuse to be used is depending on the power supply

| Power supply | Main fuse | Fuse for 24V |
|--------------|-------------|--------------|
| 230V AC | 250V/80 mAT | 250V/160 mAT |
| 115V AC | 250V/80 mAT | 250V/160 mAT |
| 24V DC | 250V/0,5 AT | - |

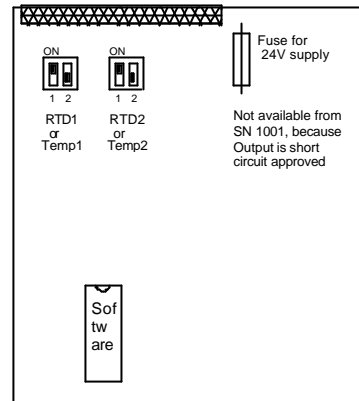

CPU circuit board with the DIP-switches for the temperature inputs

Application and Operation of the μ Flow

Basic functions of the μ FLOW 20

The μ FLOW enables a 2-fold scalar registration of the flow-signal in order to register flow rates **and** heat streams in the adequate form of presentation. Therefore both extracted measurements can be summated and stored separately.

Measurement and calculation results

The input variables are the velocity or the differential pressure supplied by a differential pressure transducer in the form of an injected current 4-20 mA or a frequency signal.

All displayed values are calculated from this variable.

The displays

The following table show the different displays. By pressing the "↓" key, it is possible to switch between the displays in descending order of the table. By pressing the "↑" key, it is possible to switch in the opposite direction. After pressing the SELECT key, the TAG-no., which can be programmed by the user, will be indicated. After pressing the SELECT key again, you get back to the normal display mode.

An example shows the following picture for mass flow m , the heat flow Q , as well as the summary (m respectiveley Q); The units have been named with kg/h; kW, t and MWh.

| Physical variable | Display in the μ FLOW display |
|---------------------|-----------------------------------|
| Mass flow | $m = 35305 \text{ kg/h}$ |
| total heat output | $Q = 28681 \text{ kW}$ |
| Mass flow | $m = 35305 \text{ kg/h}$ |
| Totalizer mass flow | $\sum m = 89.9 \text{ t}$ |

| | |
|---|---|
| Totalizer mass flow Total heat output | $\Sigma m = 89.9 \text{ t}$ $Q = 28681 \text{ kW}$ |
| Mass flow State of the alarm contacts/relays | $m = 35305 \text{ kg/h}$ A1=NORM A2=MAX |
| Branching to the subdisplays for peak value query | SELECT drücken> MIN- /MAX-Abfrage |

Example for standart and actual volumetric flow.

| Physical variable | Display in the μ FLOW display |
|--|--|
| Standard volumetric flow actual volumetric flow | $V_n = 50631 \text{ Nm}^3/\text{h}$ $V = 62123 \text{ m}^3/\text{h}$ |
| Standard volumetric flow Summator, standard volumetric flow | $V_n = 50631 \text{ Nm}^3/\text{h}$ $\Sigma V_n = 109275 \text{ Nm}^{3*}$ |
| Summator, standard volumetric flow Summator, actual volumetric flow | $\Sigma V_n = 109275 \text{ Nm}^{3*}$ $\Sigma V = 180275 \text{ Nm}^{3*}$ |
| Standard volumetric flow State of the alarm contacts/relays | $V_n = 50631 \text{ Nm}^3/\text{h}$ A1=NORM A2=MAX |
| Branching to subdisplays for peak value query | SELECT drücken> MIN- /MAX-Abfrage |

* internal summators do not have a run over, that means that depending on configuration the value of the counter can be so high, that it is not possible to indicate the unit and the formula sign. For this reason it is necessary to reset the summators in time.

Connection examples for inputs

Two illustrations are located on the rear of the μ FLOW for connection of the respective measured-value transducer. A distinction is made between two types of signal sources:

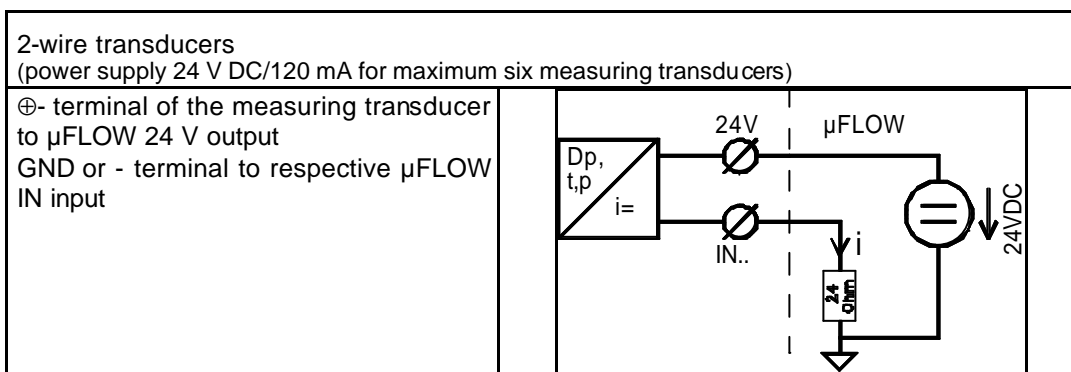

Active signal sources with an output signal 4-20 mA

⊕- of the measuring transducer to the respective μ FLOW IN input
 GND or -terminal to μ FLOW GND terminal

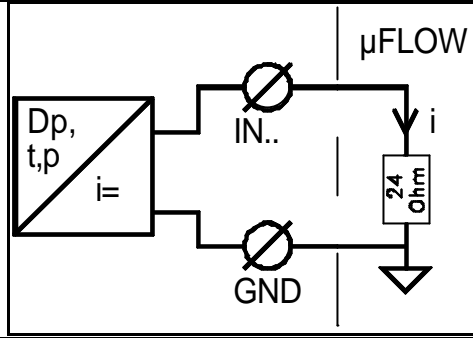

The terminals in detail

Long terminal row

| terminal | name | use |
|----------|-------|------------------------------------|
| 1 | L/DC+ | Power supply, (24 V DC + optional) |
| 2 | N/DC- | Power supply, (24 V DC - optional) |
| 3 | PE | mass |
| 4 | RXD | Transmit Data |
| | TXD | Receive Data |
| 6 | DGND | Data Ground |
| 7 | CNT | Pulse output NPN Open collector |
| 8 | DGND | GND for pulse output |
| 9 | CO | Relay 1 |
| 10 | NO | |
| 11 | NC | |
| 12 | CO | Relay 2 |
| 13 | NO | |
| 14 | NC | |
| 15 | CO | Fail-Relay |
| 16 | NO | |
| 17 | NC | |
| 18 | Freq+ | Frequency input |
| 19 | Freq- | |
| 20 | OUT2- | Analog output 2 (Option) |
| 21 | OUT2+ | |
| 22 | OUT1- | Analog output 1 |
| 23 | OUT1+ | |

short terminal row

| terminal | name | use |
|----------|-------|----------------------------------|
| 24 | B | Not used |
| 25 | A/IN5 | |
| 26 | b | |
| 27 | B | Not used |
| 28 | A/IN6 | |
| 29 | b | |
| 30 | IN4 | Not used |
| 31 | IN3 | Not used |
| 32 | IN2 | Not used |
| 33 | IN1 | Current input Flow 1 |
| 34 | GND | GND for transmitters |
| 35 | GND | GND for transmitters |
| 36 | 24V | Auxiliary power for transmitters |
| 37 | 24V | Auxiliary power for transmitters |

hint: When selecting a frequency generator, attention must be paid to the correct setting of the Jumpers located inside the unit behind the FREQ input terminals.. The Jumpers are set to TTL/CMOS inputs at the works unless otherwise specified in the parameterization log. The following table shows the correct Jumper settings.

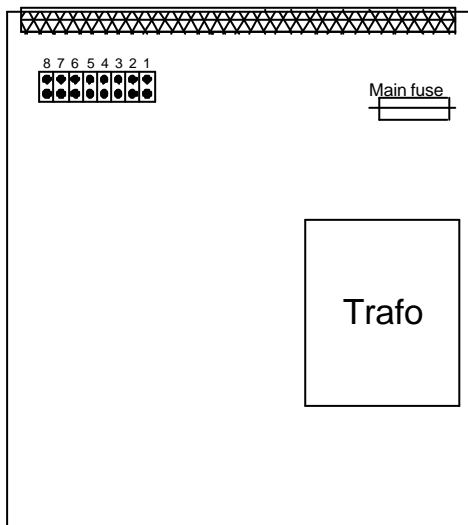

main circuit board with Jumpers for the frequency input

Programming the μ FLOW

The access levels in the μ FLOW

A distinction must be made between the operating level and the parameterization level when using the μ FLOW.

When the unit is started and initialization complete, the μ FLOW moves directly into the measuring and control mode. It is possible to branch into the parameterization level from here by simultaneously pressing the two "PROG" keys. In this way, only those parameters permitted within the framework of the set hierarchy level are released for modification.

If the unit is "BLOCKED!", an ID code (identification code) must be input before entry in the parameterization level. Otherwise, the ID code itself may be changed in the parameterization level. The hierarchy levels are as follows:

| Level | ID Code | Permitted |
|-----------|---------|--|
| Gesperrt! | 0000 | nothing |
| Operation | 1508 | Resetting the counter, query information in the menu "INFO" but change nothing |
| Engineer | 2552 | Standard level for input of process parameters; this level is sufficient for the requirements of the process engineer and the qualified operating personnel. |

The access level may be lowered in the menu option "ACCESS\LEVEL". The access levels located in the hierarchy below the currently valid level are always located here for selection. Extended access authorization is only possible by inputting the corresponding code in the menu option "ACCESS/ID-NR."

Menu and key functions

The μ FLOW menu system is organized into various levels. The selection options of a level always appear in the display.

The operating steps are the same within this programming level. Operation is always performed with one or several of the five operating keys. Their functions depend on the respective operating situation. Various instruments used in the situation given below are available for programming:

Menus consist of several selection options from which one may be selected in each case. Menu options are controlled with the vertical arrow keys " \leftarrow ", " \rightarrow " and selected with the SELECT key. The cursor indicates which menu option is currently active. The hierarchy structure of the menus is explained in section "Menu tree of the μ FLOW". Menu options may branch into submenus, "Option menus", input lines for character strings, whole numbers and reel numbers. To move from one menu to the next highest menu, the obligatory menu option "END" must be selected and confirmed with the SELECT key. It is also possible to press the two RESET keys. In this case, it is not necessary to move to the selection option "END" beforehand. It is also possible to move through all menus at high speed without having to work through the vertical arrow keys, the menu option "END" and the SELECT key. The highest menu level has a particular feature: Confirmation with the RESET keys leads at this point to quitting the parameterization level without saving the parameters in EEPROM. In this case, the changes are retained only until the next operating power interruption. This special feature is suitable for testing certain settings without overwriting the old programming values.

Option menus are merely a special form of a menu. The simplest form of an optional menu consists in the selection of the options "YES___NO". Option menus operate the same way as "proper" menus. The currently selected option appears in the first line of the display. The currently valid parameterization is therefore clear. Selection takes place by pressing SELECT, cancel without selection by pressing both RESET keys.

Input of character or letter strings: The current contents of the character string is predetermined by selecting an input function. A character to be changed is activated by one of the vertical keys and may be changed with the horizontal keys " \uparrow ", " \downarrow ". Numbers may be changed only within the preset limits. In the case of real or integer numbers, a message appears in line 1 giving the range limits of number input, the ACTUAL value appears in line 2 and then the unit of the variable to be input.

In the case of alphanumeric character strings, the first display line contains a message referring to the character string currently being processed.

The SELECT key serves in this function to accept the displayed string of digits. The RESET keys have the same meaning; in this case, input will not be deleted if these keys are pressed.

Resetting the counter

The summator and heat quantity counter may be reset by simultaneously pressing both **RESET** keys when the counter is actually being displayed. This action is prevented if the unit is locked. Incorrect or unintentional resetting is largely ruled out.

The counts are backed up in the event of power failure and are then protected by a special hardware function against unintentional overwriting.

Parameterization of the inputs

Determination of the operating mode of the flow measurement

The decision about the method can be chosen under the menu point "Params/Input/vIN1?". There you can choose if the signal at IN1 shall be root extracted or not (YES/NO)

YES (square-root extraction needed) is to choose when Differential pressure pickups with differential pressure transmitters **without** root-extracting function for the signal.

NO (no square-root extraction needed) is to choose when using Differential pressure pickups with differential pressure transmitters already **with** root extracting function for the signal or velocity pickups.

Velocity pickups are:

- vortex meters (Vortex)
- magnetoinductive flowmeters
- turbine meter or similar

Differential pressure pickups are:

- pitostatic tube sensors
- plates
- nozzles

Parameterization and setting of frequency signals

When selecting a frequency generator, attention must be paid to the correct setting of the DIP switches located inside the unit behind the FREQ input terminals. The switches are set to TTL/CMOS inputs at the works unless otherwise specified in the parameterization log. The following table shows the correct switch settings:

| Signal type | Switches (in accordance with top view) | | | | | | | |
|-------------------------------|--|---|---|---|---|---|---|---|
| | 1 | 2 | 3 | 4 | 5 | 6 | 7 | 8 |
| TTL, CMOS, pulse | x | x | 0 | 0 | 0 | 1 | 1 | 0 |
| Puls with log.0 gt. than 1,4V | x | x | 0 | 0 | 0 | 0 | 1 | 0 |
| Puls with log.0 gt. than 0,2V | x | x | 0 | 0 | 1 | 0 | 1 | 0 |
| Open Collector NPN | x | x | 1 | 0 | 0 | 0 | 1 | 0 |
| Open Collector PNP | x | x | 0 | 0 | 0 | 0 | 1 | 1 |
| Coil (high impedance) | x | x | 0 | 1 | 0 | 0 | 0 | 0 |
| Coil (low impedance) | x | x | 0 | 1 | 0 | 0 | 0 | 1 |

The following parameters may be set in the parameterization menu:

the pulse value (menu option "PARAMS\INPUT\V/PULSE"): The volume corresponding to the pulse must be specified here. In the case of vortex frequency counters, this is typically specified on the rating plate; in the case of other measuring units the volume must be calculated in accordance with the type specification; the maximum flow volume V_{max} (menu option "PARAMS\INPUT\MAXFLOW"):

Specification of this value is important for low flow cutoff specification described below. If this value is not specified, creep quantity suppression will not function or will function incorrectly.

Parameterization of current signals (4-20 mA)

Parameters which can be set are:

Lower measuring-range-limit-value (menu option "Params\Input\Minflow")

Upper measuring-range-limit-value (menu option "Params\InputMaxflow")

Choosing the menu option "Params\Input\vIN1? NO" will effect the linear interpolation between the upper and lower measuring-range-limit-value. Otherwise the on 1 standardized Input-signal will be root-extracted and the root-extracted result then will be drawn for the linear interpolation between the Maxflow and the Minflow.

Further important parameters for the parametrization of the flow inputs

The factor for the 2nd flow-depending scale-measurement value (menu option: "\Params\Input\Factor") which refers to the scale measurement of the 1st flow measurement value. This means, the 2nd value will be determined by multiplying the 1st value with the value under "FACTOR".

Dealing with the outputs

The analog outputs

It makes sense to furnish the μ FLOW 20 with an analog output related to the flow. This analog output is electrically isolated from the rest of the system and drives a load of max. 500 Ohm. Their resolution is 1000 steps ($2\mu\text{A/Schritt}$)

Setting the characteristics and the full-scale values

Output characteristics (menu option "\Params\Output\Analog\Charakt\"): It is possible to set the outputs to 0 - 20 mA (menu option "\\PARAMS\OUTPUT\ANALOG\CHARAKT\0-20 MA") or 4-20 mA ("life zero") (menu option "\\PARAMS\OUTPUT\ANALOG1\CHARAKT\4-20 MA") independently of each other. Lower full-scale value (menu option "\PARAMS\OUTPUT\ANALOG1\LO-VAL"): The setting is made referred to the assigned physical variable and is therefore without dimension; setting limits 0...2000000.

Upper full-scale value (menu option "\PARAMS\OUTPUT\ANALOG1\HI-VAL"): The setting is made without dimension as for the lower full-scale value; setting limits 0...2000000.

The relay outputs

The functions of the μ FLOW 20 are fix and are related to the 1st flow value. Relay 1 functions as minimum-alarm, relay 2 as maximum-alarm. The switch value has to be input explicitly under menu option "Params\Output\Relay\REL.1", i.e. ".....REL.2

The setting results dimensionless in connection with the relating physical variable; setting limits 0...2.000.000.

The FAIL-contact is no subject to configuration, as it is not under arbitrary control of the operating program.

The counting pulse

The signal from the back "CNT" terminal is the pulse of an open collector which is always given when the assigned added quantity or energy is increased by 1. The pulses therefore occur irregularly and do not correspond to the current flow rate.

The "CNT" output is **not** connected to any voltage. Therefore, commercially-available counters may be connected which mostly have supply voltages for the pulses of relay contacts or open collectors available at their inputs. Should this not be the case, connect in accordance with the following connection diagram:

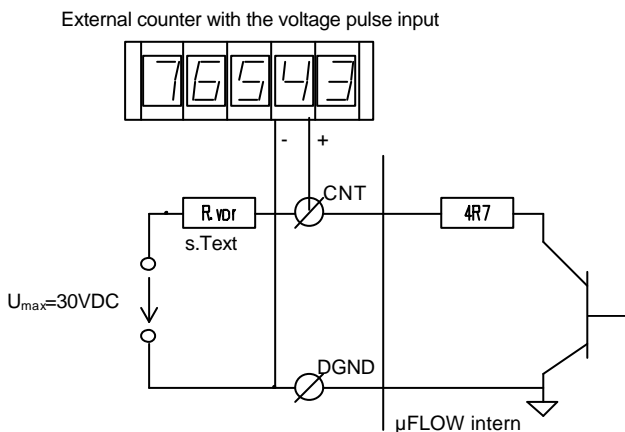

connection diagram:

The pulse pulls the voltage to DGND. The transistor is a generously dimensioned Darlington model which functions here as a current sink. This current is limited by the internal series resistor so that only an output of approx. 1 W can be switched. It is therefore necessary to connect an appropriately dimensioned external series resistor so that the permissible switching output is not exceeded. In general, a series resistor in the range of 1 to 10 K should be used thus guaranteeing safe operation with voltages of more than 24 V DC. The counting pulse is permanently assigned to the flow.

Setting the pulse duration

Pulse duration (menu option "PARAMS\OUTPUTS\CNTPULS\PULSWID."): The setting possibilities are 10, 50 or 100 milliseconds; this should be set depending on the specifications of the connected counter.

RS232 Interface

Using the interface

The RS232 interface supports data logging operation i.e. the recording of measurement results with the PC. It is planned for the future to extend the software to allow configuration of the μ FLOW via the RS232 interface as well as the combination of several μ FLows in one system.

Connection and control of the μ FLOW with an industrial PC

The μ FLOW and PC are connected via a three-core cable with a maximum length of 10 m. The TxD terminal on the μ FLOW must be connected with the RxD line on the PC interface and conversely the RxD terminal on the μ FLOW with the TxD line on the PC.

The selection of a suitable interface for the PC depends on its concrete assignment with serial COM interfaces. If the option exists, the terminal software used should set the COM interface to operations *without log* or *with XON/XOFF log*. Should only a hardware log be planned, the corresponding handshake lines on the serial interfaces must be shorted.

Parameters

For reasons of clarity, the setting possibilities of the parameters are limited to the influencing variables which are really important for operation of the serial interface. The number of data bits and stop bits and the parity may therefore not be set. In accordance with the transfer parameters selected in most application cases, the μ FLOW transmits with

- 8 data bits
- 1 stop bit
- no parity
- with XON/XOFF log

The baud rate and the time between two transfers may be set.

Setting the baud rate

The transfer rate may be influenced by the baud rate. The baud rate determines transfer reliability in critical cases. Reducing the rate may provide a remedy in the event of data transfer with interference. (This procedure is selected for example for so-called "Overseas connections" in fax units.)

The baud rate is set in the menu "/PARAMS/OUTPUTS/RS232/BAUD" on the μ FLOW. 4800 and 9600 bauds are possible. Operation with 9600 baud should be attempted at first.

Setting the duration of the transmission cycle

The transmission cycle directly influences the occurring data flow. The data to be saved should be reduced to a reasonable quantity since data flows normally in slow processes. For this reason, the μ FLOW supports a minimum time period of 5 seconds. However, care still needs to be taken because approximately 30 characters per transfer gives rise in this case to 360 characters per minute, 21600 characters per hour and 518400 characters per day. This is not a sensible amount for the majority of cases. In addition to the large amount of memory space required, evaluation of this data in particular is made significantly more difficult.

Log

The low absolute transfer rates should not give rise to conflicts in communication between the μ FLOW and the PC. A log is actually superfluous for this reason. However, the transmission activity of the μ FLOW may be interrupted by an XOFF signal transmitted by the PC and may then be continued with an XON signal. Should the interruption last longer than one transmission cycle, the data transmitted inbetween are ignored.

Data format

The μ FLOW transmits text character strings (ASCII) with information about the current flow, the status of the summator and the primary state data pressure and temperature. The individual values are separated by blanks (ASCII code 32).

A typical line may look as follows:

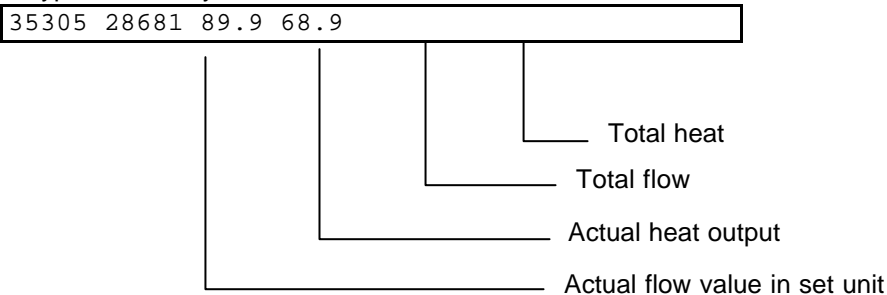

Example application of the generated file with Microsoft-Windows

The following is intended to provide a description of example measuring data acquisition and processing with a standard PC using Microsoft-Windows. Other systems offer generally comparable performances so that the following instructions are transferrable in principle.

Data input with TERMINAL

MS-Windows 3.1 offers a simple terminal program in its system resources which is, however, well suited for data acquisition from μ FLOW. In the menu option "Setting/Data transfer", the following settings are made in accordance with the above versions: Baud rate 9600; data bits: 8; parity: none; log: none; stop bits: 1; connection: in accordance with the interface assignment; plausibility check: OFF; carrier signal detection: OFF.

Data should already appear on the screen after a waiting period between two transmission cycles have expired if a connection to the μ FLOW exists. When performing tests, it is practical to set this cycle time on the μ FLOW to 5 seconds in order to obtain a prompt reaction.

After performing connections and correctly setting all parameters, data acquisition can now take place without any problems. Memory setting on hard disk is performed in the menu option "Transfer/Text file received". Here you must enter the directory and name of the measurement file to be created corresponding to usual practice when using Windows 3.1. Acquisition then takes place immediately. Please observe any possible conflicts with other application programs. It is recommended not to run any other programs during measuring data acquisition. Windows is not a real-time multitasking system developed for such tasks.

Data acquisition is completed in the window for data reception by clicking on the "Abort" button. The file is now closed and may be worked on.

Processing data with WINWORD 6.0

The file created with the terminal is in table format. The individual fields are separated by a blank. The entire file may be entered with a text processing program such as WINWORD 6.0. The entire file can be transferred to a WINWORD table by selecting the Winword menu option "Table/Convert text to table" after marking the entire text with "Ctrl" and "Num 5" ("5" on the numerical PC keyboard). Winword 6.0 offers the possibility of working with this table or saving it and working in another Windows program. The data stock can be transferred, for example, by copying the file into the interim memory and then inserting it into a user program such as EXCEL, PARADOX or similar.

Processing data with EXCEL 5.0

EXCEL 5.0 offers the possibility of entering texts structured in tables. Use here the command "File/Open" and select the file type "Text files (*.prn;*.txt;*.csv)". After clicking the "OK" button, EXCEL opens the text assistant. The original file can then be specified in several steps. First select here the "original file type" "separated": In this way, EXCEL is informed that the numbers contained in the text lines may have a varying number of digits. Now press the "CONTINUE>" button. The second step of the text assistant permits EXCEL to specify a separator. The correct setting is the blank " ". The preview permits you to check separation by EXCEL 5.0. You have probably input the German decimal comma as the decimal character. EXCEL is then unable to interpret the corresponding μ FLOWdata as numbers since this uses the standard

international decimal point. In this case, you may temporarily change the decimal character to the decimal point in windows system control under the feature "Country settings" so that the number chains supplied by μ FLOW can be correctly interpreted by EXCEL.

By clicking on the "CONTINUE>" button, the 3rd step of the EXCEL text assistant is performed. Here you may delete individual columns so that you are then able to selectively further process only the μ FLOW data.

The file is formatted in EXCEL format by clicking "END" and evaluation may begin. Do not forget to save the processed file in EXCEL format if possible.

Miscellaneous

Programming the measuring point number

The μ FLOW offers the possibility of determining a measuring point number (TAG number) which may be made visible by the operating staff at any time - practical particularly when using separate units at the same time. This is programmed in the menu option "\PARAMS\TAG-NR."

The TAG number may be queried at the operating level by pressing the SELECT key. The display is cancelled when the SELECT key is pressed a second time.

Querying the software version number and unit serial number

It may be practical to know important unit data in the event of queries from the manufacturer or the sales company. These may be queried in the menu "\INFO ":

- Software version number (menu option "\INFO \VERSION ")
- Unit serial number (menu option "\INFO \SER.NR.")

