

SDF-flow sensors - FASTLOK N -

Operating and Mounting Instructions

Contents:

- 1. Incoming inspection 2
- 2. Mounting Instructions 2
- FASTLOK N-sensors with draw-out mechanism (up to PN16) 2
 - Standard FASTLOK N-types are equipped with a hand crank to activate the mounting mechanism..... 2
 - 2.1. Determination of the mounting location 3
 - 2.2. Determination of the mounting position 4
 - 2.2.1. Horizontal pipe run 4
 - 2.2.2. Vertikal pipe run and existing risk of condensation 4
 - 2.3. Orientation of the SDF-sensor 4
 - 2.4. Fitting of the mounting parts 5
 - 2.5. Further steps of mounting the FASTLOK N - sensor 6
 - 2.5.1. Mounting and positioning of the FASTLOK N - sensor 6
 - 2.5.2 Removal of the FASTLOK N - sensor 7
- 3. Connecting the differential pressure transmitter to the sensor 7
 - 3.1. Sensor with mounting plate for direct connection of the transmitter to the sensor 7
 - 3.2. Sensor with connector nipples for connection of the transmitter via differential pressure lines 8

1. Incoming inspection

Each delivery leaving our company is carefully inspected to the best knowledge. On the packing list included, the employee responsible for the delivery confirms with his/her signature that the delivery contains all the items specified in the delivery documents.

Nevertheless, it is necessary for the customer to carry out a crosscheck as soon as possible after receipt of the delivery. Only then can justified complaints be settled quickly and without further discussions.

On receipt of delivery please check:

- if the rating plate corresponds to that indicated on the delivery note
- if the version delivered corresponds to the version orderd, especially with respect to sensor length, sensor material and mounting parts, insofar as this is possible
- if the scope of delivery corresponds to the quoted delivery-list.

2. Mounting instructions

FASTLOK N-sensor with draw-out-mechanism (up to PN16)

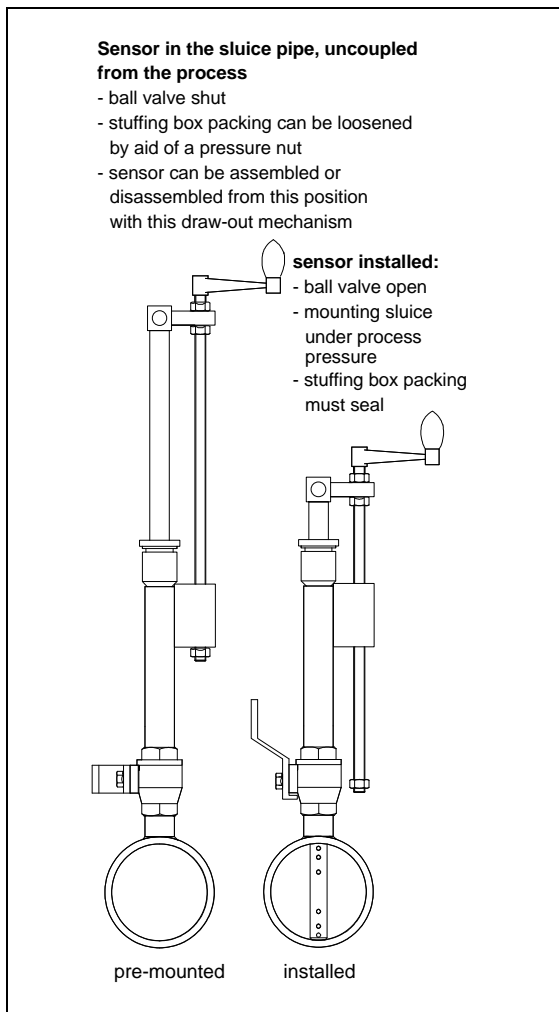

The SDF-sensors type FASTLOK N are suitable for safe assembly and disassembly under higher pressure (up to PN16, 150 lbs) by just one person. This mechanism enables a controlled disassembly, where self-locking until the shut-off of the pipe and complete disassembly is possible at any time. With the valves of the pressure transmitter or the primary shut-off devices the residual pressure contained in the mounting facility can be relieved before complete disassembly of the sensor. Standard FASTLOK N-types are equipped with a hand crank to activate the mounting mechanism.

Figure 1

The version shown in figure 1 has got a thread-nipple as differential pressure connection

2.1. Determination of the mounting location

Determine the longest straight section of the pipeline or channel and divide this into upstream and downstream distance respectively according to the table below.

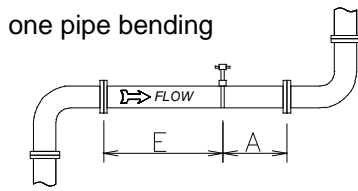
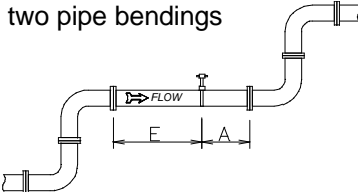
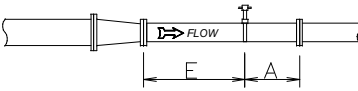
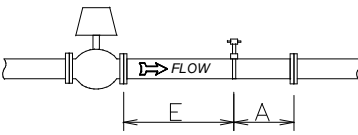
Required steadying zones		
Pipe run	Up-stream	Down-stream
<p>one pipe bending</p> 	7*ID	3*ID
<p>two pipe bendings</p> 	10*ID	3*ID
<p>reduction</p> 	7*ID	3*ID
<p>controlling element</p> 	20*ID	5*ID

The indicated upstream and downstream distances are standard values. They can be shortened by „intelligent“ installation. What does „intelligent installation“ mean?

Example 1: Installation of the sensor behind a bend.
The flow profile mainly deforms on the level of the pipe bend. Therefore the sensor should also be installed on this level in order to actually detect the velocity variations at the different measuring points.

Example 2: Correct installation is impossible due to structural conditions at the measuring point.
This can be remedied by correction of the k-factor of the SDF sensor (see section „fundamental calculation principles“). This is done by measuring the flow velocity at the sensor mounting location by means of a test apparatus (e.g. a pitostatic tube) and comparing this value with the value displayed on the stationary measuring system. If deviations occur, the application-specific k-factor must be calculated from the calculation formulae and the parameters of the measuring system must be re-adjusted. When required, details can be taken from a special application report.

If you require more information, please contact our consulting and commissioning service.

Important

Due to the special way of mounting the FASTLOK N sensor, more clearance is required for mounting and dismantling than for standard versions of the SDF-sensors. Take this into consideration when selecting the mounting location. The space required in the draw-out direction of the sensor is calculated as follows:

$$3 \times ID + 1000 \text{ mm}$$

(ID= internal diameter of the pipeline)

Take into account obstructions existing in front of and behind the selected mounting location. Passive elements (e.g. bends) cause less interference than active elements (e.g. fans). Harmonic changes in the pipe run (bends with large radii, reductions according to DIN) are more favourable than sudden or less harmonic changes (corners, stops). Contact the manufacturer or responsible sales engineer if necessary!

2.2. Determination of the mounting position

2.2.1. Horizontal pipe run:

- Gases:** Mount the sensor in the area between position 9.30 (a.m.) and 2.30 (a.m.).
Liquids: Mount the sensor in the area between position 3.30 (a.m.) and 8.30 (a.m.).

2.2.2. Vertical pipe run and existing risk of condensation:

- Gases:** Incline the sensor mounting position slightly to enable the condensate to flow away from the sensor head back into the process.
Liquids: Incline the sensor mounting position slightly to enable air or gas bubbles to return into the process.

2.3. Orientation of the SDF flow sensor

The construction of SDF flow sensors (and also FASTLOK sensors) is completely symmetrical. For this reason it is irrelevant which of the apertured sensor sides faces the flow. Consequently the arrow indicating the flow direction only shows whether the SDF flow sensor is designed for horizontal or vertical flow. In addition the connections are marked with the letters **LK** (left sensor chamber) and **RK** (right sensor chamber) for horizontal pipelines and with **OK** (upper chamber) and **UK** (lower chamber) for vertical pipelines. The construction of the sensors ensures that the connections are always on the same level. That means that the flow indicating arrow on sensors for vertical pipelines is shifted by 90° with relation to the connections. The sensors must be mounted with the engraved letters being normally readable (in upright position).

The following table shows the allocation of sensor chamber and transmitter connection depending on the pipe run and the direction of flow.

The piping or mounting of the transmitter must be carried out accordingly.

pipe run	flow direction		+ side of transmitter	- side of transmitter
horizontal	from left to right	→	LK	RK
horizontal	from right to left	←	RK	LK
vertical	from top to bottom	↓	OK	UK
vertical	from bottom to top	↑	UK	OK

2.4. Fitting of the mounting parts

On delivery the complete FASTLOK N sensor unit including sluice pipe and securing chain is pre-assembled and must be disassembled before mounting it into the pipeline.

For **initial mounting** of a FASTLOK N sensor the pipeline must be **depressurized** and **emptied**, if necessary, to mount the welding socket! Afterwards the sensor can be removed under process conditions.

At the mounting location determined a hole must be bored or burned into the pipe wall:

SDF-AN-10: \varnothing 18mm

SDF-AN-22: \varnothing 31mm

SDF-AN-32: \varnothing 38mm

SDF-AN-50: \varnothing 57mm

The welding nipple for the ball valve must be fastened in such a way that the bore hole in the pipeline remains completely unobstructed. Align the internal boring of the welding nipple in a position perpendicular to the axis of the pipeline and then weld the welding nipple to the pipeline.



If the sensor is fitted with an **end support** the following mounting procedure is used:

First the mounting location of the end support is determined; it is positioned directly opposite the mounting part.

Recommended procedure for determining the opposite point:

First mark the center of the mounting part to be installed on the pipeline. Then pass a tape of at least 30 mm width and appropriate length tightly around the pipeline, and align it in such a way that after one rotation it exactly covers the first layer. Start by holding one end of the tape to the point marked on the pipeline. Mark the tape at the point which after one rotation is directly adjacent to the marked mounting part centre. The distance from the start of the tape to this point is equal to the outer diameter of the pipeline. Remove the tape, determine the centre between the start of the tape and the point marked on the tape, and mark the centre of the tape. Place the tape around the pipeline again as described above. The point marked last on the tape (centre) is the position exactly opposite the mounting part. Finally you only have to transfer this point to the pipeline. If there is no tape available you can also use a cord to determine the diameter. In this case it is important to check the axial alignment of the cord by measuring the distance to the next flange.

The mounting part is then mounted as described above.

At the opposite point (see above) a hole of appropriate size is subsequently bored or burned into the pipe wall. Select the appropriate diameter from the following table:

sensor type	end support with pipe thread and hood (SC)
SDF-...-22	28 mm
SDF-...-32	36 mm
SDF-...-50	54 mm

The end support has to be attached and positioned in a way that the end support and the previously welded mounting part are align. This will avoid canting of the sensor during installation.

Make sure that the bore-hole stays completely open and weld the end support to the pipe.

Tips to align the end support:

After the hole is being bored, lead through the sensor or a straight piece of pipe with an according external diameter and push the end support loosely over the sensor or pipe end sticking out. After aligning the end support (do not cant !), attach it to the pipe. Remove the sensor, resp. the piece of pipe and finish welding.

After the mounting of the sensor is done, close the end support with the enclosed cap.

2.5. Further steps for mounting the FASTLOK N- sensor

The supplied ball valve is screwed into the socket welded to the pipeline and then the sluice pipe with stuffing box packing is screwed and sealed into the ball valve. It is absolutely essential to adjust the parts as follows:

The sluice pipe has got at its end with the stuffing box a guide with inner thread for the spindle. After the sealing of the screw is done, this spindle-guide has to be placed exactly radial to the pipeline axle (s. figure 1). This means they point to the side, in respect to the pipe run. This ensures that the sensor with its holes will later be inserted and streamed correctly

As soon as the ball valve has been sealed, it can be closed and the process pressure can be applied to the pipeline!

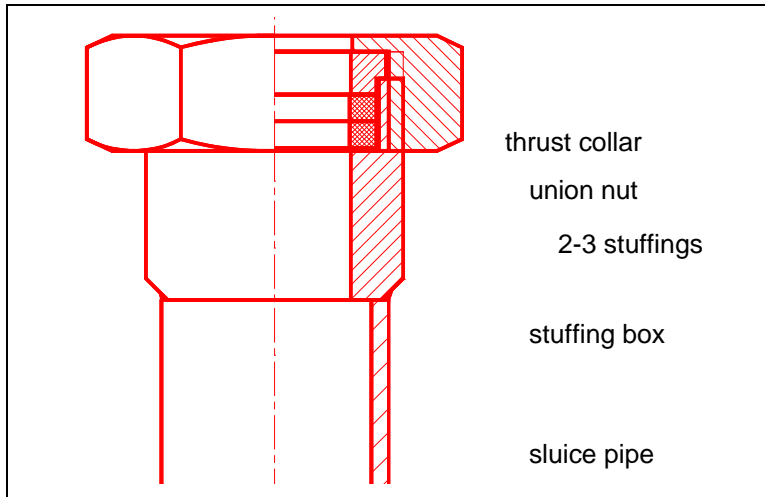

Figure 2

On delivery the packing has already been placed in the stuffing box, and an extra set accompanies the delivery.

2.5.1. Mounting and positioning of the FASTLOK N - Sonde

The FASTLOK-N sensor can be mounted under process conditions.

If the pipeline is already under process pressure the **ball valve must remain shut** until step 5

1. After loosening the union nut as far as necessary insert the sensor tip carefully into the stuffing box without tilting.
2. Without exerting pressure carefully insert the sensor until it reaches the ball valve.
3. Tighten the stuffing box sufficiently so that the sensor shaft on the one hand is sealed and on the other hand can be moved inside the stuffing box without excessive effort.
4. In this position the sensor is secured by hooking the securing chain fastened to the stuffing box into the lug on the sensor head.
5. The ball valve is now **carefully** opened. If the stuffing box is not tight then tighten it more firmly or shut the ball valve immediately. If it is not possible to further tighten the stuffing box, insert another stuffing under the thrust collar.
6. When the stuffing box is tight the sensor is pushed further through the **completely open** ball valve until the sensor tip **touches** the opposite wall of the pipeline.
7. When mounting a version with **end support** the sensor will be inserted until the distance between pipe-wall and the upper edge of the sensor head, resp. flange plate, is reached according to the data you will find on the backside of the type plate. Now the sensor tip reaches approx. 30mm into the end support.
8. Again check the tightness of the stuffing box and tighten more firmly if necessary.

Important mounting instructions:
First tighten stuffing box, then carefully open ball valve !!!

2.5.2. Removal of the FASTLOK N - sensor

The FASTLOK N-sensor can be removed under process conditions.

1. With the hand crank the sensor will be drawn out of the pipe to the extent that the sensor tip still remains in the sluice pipe. Eventually the stuffing box has to be loosened a little already, but only as much as necessary and very carefully (because of medium coming out) !
2. **Close** ball valve **completely**, if necessary secure against accidental opening.
3. After loosening the thread pin, remove nut from the lower end of the spindle.
4. Loosen the stuffing box completely and crank out the sensor until the spindle is not held by it's guidance anymore.
5. Remove the sensor completely from the sluice pipe by hand, without wedging it.

Important removal instruction:
First close the ball valve completely, then fully loosen the stuffing box, and draw out the sensor !!

3. Connecting the differential pressure transmitter to the sensor

3.1. Sensor with mounting plate for direct connection of the transmitter to the sensor

Sensors with a mounting plate for direct connection of the transmitter offer the most simple and economical way of connecting sensor and transmitter. Sensor, three-way manifold and transmitter thus form a kind of "sandwich" connected by means of 8 screws (4 on either side). This arrangement requires that the permissible temperatures at the transmitter diaphragm are not exceeded. The \oplus -side of the transmitter must be connected to the sensor flow side, i.e. the front side of the sensor when looking in the direction of the arrow (see figure). Both sealing faces - the one between sensor and valve block as well as the one between valve block and transmitter - must be fitted on one side with a sealing ring which must be inserted in the groove provided for this purpose. These sealing rings are part of the scope of delivery.

The three-way manifold is usually delivered mounted to the transmitter. The seals are inserted in the grooves and fixed with adhesive tape which, at the same time, covers the bore holes. Before mounting the tape must always be removed.

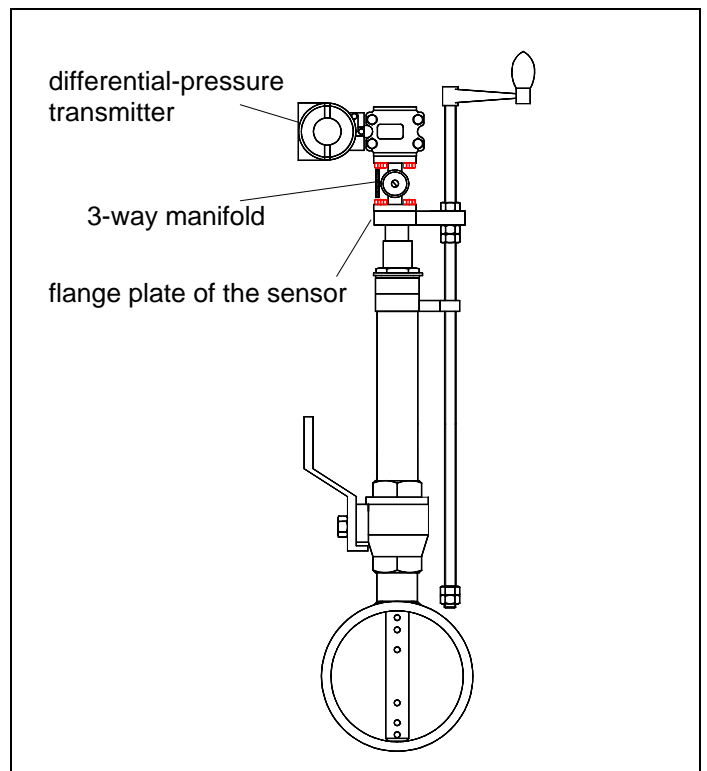

Thus a complete parts list for the commissioning of the sensor must comprise the following:

- sensor including mounting parts for insertion into the pipeline (welding socket, ball valve, sluice pipe)
- 1 ea. three-way manifold (version for mounting between flanges) for direct mounting to the transmitter and sensor including gaskets and screws
- 1 ea. differential pressure transmitter; a mounting support is not required!

3.2. Sensor with connector nipples for connection of the transmitter via differential pressure lines

If the transmitter is not mounted directly onto the sensor, it is connected via differential pressure lines. Usually pipes are used which are connected to the sensor and the transmitter by means of screwed connections. Normally screwed connections with cutting or clamping rings are used which allow the process connections to be adapted to the selected pipe connection with a diameter of 12 mm. On request these screwed connections can be obtained from your dealer.

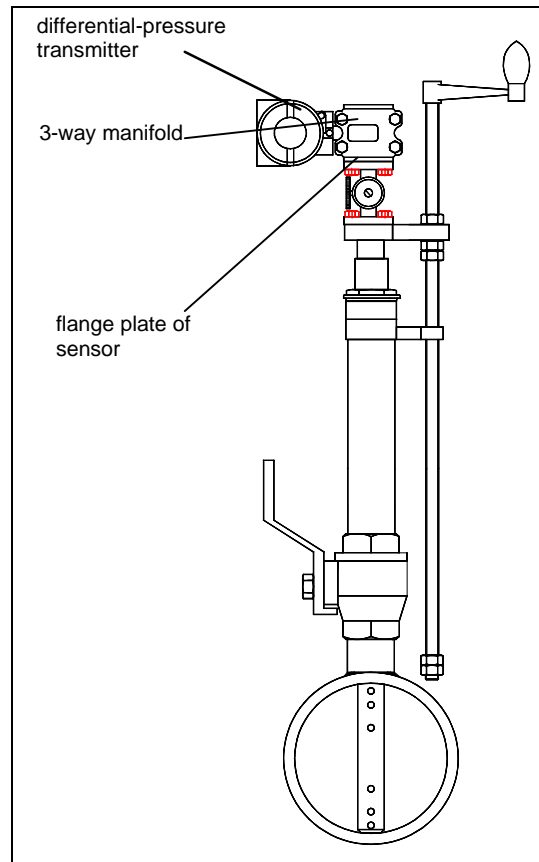

Thus a complete parts list for the commissioning of the sensor must comprise the following:

- sensor including mounting parts for insertion into the pipeline (welding socket, ball valve, sluice pipe)
- 2 ea. ball valves for the primary shut-off of the differential pressure lines of the sensor
- 4 ea. fittings for adaption of both the process connections to the 12 mm diameter pipeline and the pipeline to the three-way manifold (1/2" 14 NPT female thread)
- 1 ea. three-way manifold for direct mounting to the transmitter with 1/2" 14 NPT female thread process connection including all screws and gaskets as well as, if required, the necessary oval adapters
- 1 ea. differential pressure transmitter with a pipe or wall mounting support
- and an adequate length of pipeline with 12 mm diameter

Please inform your responsible sales engineer or representative if you wish the commissioning of the sensors to be carried out.